



Financial Crimes Enforcement Network (FinCEN)

**Report of Cash Payments Over \$10,000 Received  
in a Trade or Business (FinCEN Form 8300)  
Electronic Filing Requirements**

**XML Schema 2.0**

**User Guide**

DEPARTMENT OF THE TREASURY  
FINANCIAL CRIMES ENFORCEMENT NETWORK (FINCEN)

## 0. Revision History

Version Number	Date	Change Description
1.0	March 2019	Initial version
1.1	10/1/2019	<p>Electronic XML Filing Instructions (Attachment C)</p> <ul style="list-style-type: none"> <li>• General Instructions: 14. Addresses <ul style="list-style-type: none"> <li>○ Added the following note at the end of the instructions: "NOTE: The ISO 3166-2 country list contains the code "UM" that stands for the United State Minor Outlying Islands. Using "UM" in country fields is prohibited. These islands are uninhabited. As such they have no addresses."</li> </ul> </li> </ul> <p>Attachment E – Sample Data (New)</p> <ul style="list-style-type: none"> <li>• Added new Attachment E – Sample Data section to the XML User Guide. It includes a link to sample data corresponding with this form type.</li> </ul>
1.2	08/01/2021	Added Error Code F60 – "The namespace prefix for the element is invalid."

**Contents**

0. Revision History.....iii

Contents.....iv

1. Introduction ..... 1

2. FinCEN Form 8300 XML Schema Overview ..... 1

    2.1. File Organization..... 1

        2.1.1. XML declaration (prolog)..... 1

        2.1.2. EFilingBatchXML ..... 1

        2.1.3. Activity..... 2

        2.1.4. Party ..... 2

        2.1.5. CurrencyTransactionActivity..... 4

3. FinCEN Form 8300 XML Batch Reporting Requirements ..... 4

    3.1. Element Definition Overview ..... 4

    3.2. Batch Validation (Form & Fit) Overview ..... 5

4. FinCEN Form 8300 XML Element Requirements ..... 6

    4.1. XML declaration/prolog ..... 6

    4.2. EFilingBatchXML Elements ..... 6

    4.3. Activity Elements..... 7

    4.4. ActivityAssociation Elements ..... 10

    4.5. Party Elements ..... 12

        4.5.1. PartyName Elements..... 16

        4.5.2. Address Elements..... 21

        4.5.3. PhoneNumber Elements..... 26

        4.5.4. PartyIdentification Elements..... 27

        4.5.5. PartyOccupationBusiness Elements..... 32

    4.6. CurrencyTransactionActivity ..... 34

        4.6.1. CurrencyTransactionActivityDetail ..... 37

    4.7. ActivityNarrativeInformation Elements..... 43

5. Party Elements by Party Type ..... 45

    5.1. Party Record Examples ..... 46

        5.1.1. Transmitter..... 46

        5.1.2. Transmitter contact ..... 46

        5.1.3. Individual from whom the cash was received..... 46

        5.1.4. Person on whose behalf transaction conducted ..... 47

        5.1.1. Business that received cash ..... 48

        5.1.1. Authorized official..... 48

5.1.1.	Contact for assistance.....	48
6.	FinCEN Form 8300 XML Acknowledgement Format.....	49
6.1.	XML File Structure .....	49
6.1.1.	XML declaration/prolog.....	49
6.1.2.	EFilingBatchXML .....	49
6.1.3.	EFilingSubmissionXML.....	50
6.1.4.	EFilingActivityXML.....	50
6.1.5.	EFilingActivityErrorXML.....	51
6.2.	Acknowledgement XML Example .....	53
7.	Attachment A – Error Descriptions.....	55
7.1.	General errors.....	55
7.2.	Document Errors .....	57
7.3.	Individual from whom cash was received (Part I) & Person on whose behalf this transaction was conducted (Part II) Errors .....	59
7.4.	Business that received cash (Part IV) & Comments Errors.....	59
7.5.	Transmitter & Transmitter Contact Errors .....	59
8.	Attachment B – Error Correction Instructions.....	61
9.	Attachment C – Electronic XML Filing Instructions.....	63
10.	Attachment D – Secure Data Transfer Mode Filers.....	75
11.	Attachment E – Sample Data .....	76

## 1. Introduction

The Report of Cash Payments Over \$10,000 Received in a Trade or Business (FinCEN Form 8300) Electronic Filing Requirements XML Schema 2.0 User Guide outlines the business and validation rules to support the electronic batch transmission of the FinCEN Form 8300. Electronic filing of this report will be through the Bank Secrecy Act (BSA) E-Filing System operated by the Financial Crimes Enforcement Network (FinCEN). BSA E-Filing users who intend to file the FinCEN Form 8300 batch XML should be familiar with FinCEN regulations, Extensible Markup Language (XML) and the FinCEN XML schemas. For more information, please go to [bsaefiling.fincen.treas.gov](https://bsaefiling.fincen.treas.gov).

## 2. FinCEN Form 8300 XML Schema Overview

Before you begin submitting your BSA data to FinCEN's BSA E-Filing System ([bsaefiling.fincen.treas.gov](https://bsaefiling.fincen.treas.gov)) via XML batch, you must first review the required schemas to assist you with constructing and testing your XML batch file before submitted to FinCEN for processing. These schemas define the requirements by which the FinCEN Form 8300 XML batch file must be constructed, such as which elements are required and which are not required, what are the appropriate values you may enter for certain elements, and what sequence the elements should appear in when building the batch. Please visit [https://www.fincen.gov/sites/default/files/schema/base/EFL\\_8300XBatchSchema.xsd](https://www.fincen.gov/sites/default/files/schema/base/EFL_8300XBatchSchema.xsd) to access the FinCEN XML 2.0 batch schema file.

### 2.1. File Organization

This section describes the general formatting requirements for FinCEN Form 8300 XML batch reporting. The diagrams that follow provide a visual representation of the XML batch file layout from a high level perspective.

#### 2.1.1. XML declaration (prolog)

The XML declaration specifies the XML version and character encoding used in the file. It must appear on the first line of the file.

#### 2.1.2. EFilingBatchXML

This is the root element and serves as the container for all FinCEN Form 8300 documents recorded in the batch. It must be the first element recorded in the file.

The EFilingBatchXML element is parent to the <Activity> element. This complex element is the container for each FinCEN Form 8300 document in the batch. All BSA data related to a single FinCEN Form 8300 document must be recorded within the <Activity> element. The count of <Activity> elements in the batch will depend on the count of FinCEN Form 8300 documents being reported.

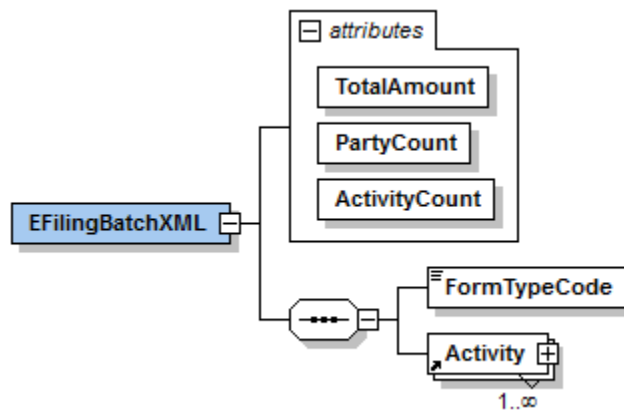

### 2.1.3. Activity

Each FinCEN Form 8300 document in the batch must begin with the <Activity> element. This element identifies all information related to a single FinCEN Form 8300. This information includes the transmitter of the batch file, the transmitted contact, the individual from whom the cash was received, the person on whose behalf this transaction was conducted, the business that received cash, the authorized official, the description of the transaction, the method of payment, and any additional comments associated with the form. There is no limit to the number of <Activity> elements that may be recorded in the batch. However, the total size of the batch file must not exceed 60MB.

The <Activity> element is parent to the following complex element(s):

- **ActivityAssociation.** This element is the container for the type of filing (i.e. Initial report or Corrects/amends prior report) for the FinCEN Form 8300.
- **Party.** This element is the container for any person (individual or entity) associated with the FinCEN Form 8300, specifically, the transmitter [of the batch file], the transmitter contact, the individual from whom the cash was received, the person on whose behalf this transaction was conducted, the business that received cash, and the authorized official.
- **CurrencyTransactionActivity.** This element is the container for information about transaction, such as the total cash in amount, the transaction date, etc.
- **ActivityNarrativeInformation.** This element is the container for any comments associated with the FinCEN Form 8300.

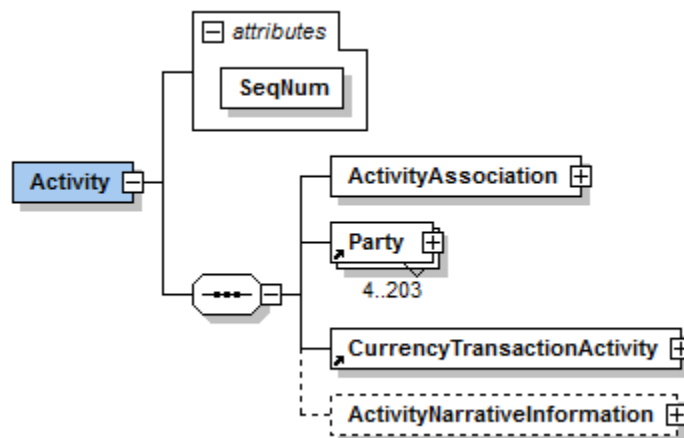

### 2.1.4. Party

Each FinCEN Form 8300 activity in the batch must include a separate Party element identifying the following persons:

- Transmitter (required, one only).
- Transmitter contact (required, one only).
- The individual from whom the cash was received (required, multiples permitted up to 99).
- The person on whose behalf this transaction was conducted (required if available, multiples permitted up to 99).
- The business that received cash (required, one only).
- The authorized official (required if available, one only).
- The person to contact for assistance (required if available, one only).

A maximum occurrence of 203 total Party elements may be recorded at the activity level for each FinCEN Form 8300 activity in the batch.

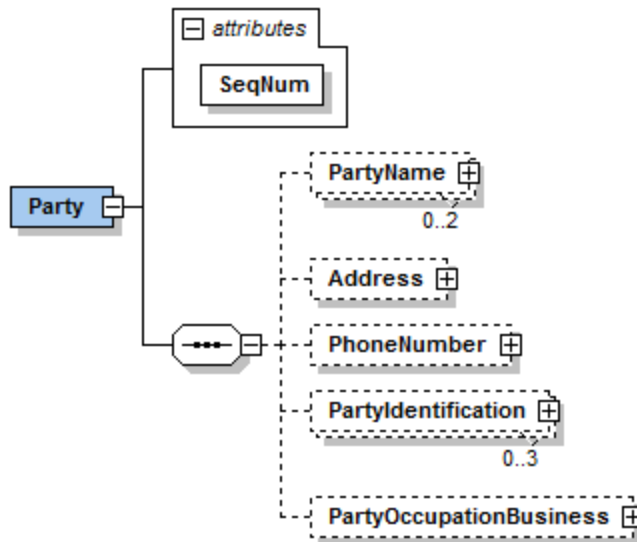

#### Transmitter (Required | 1)

This is the person (individual or entity) handling the data accumulation and formatting of the batch file. Each FinCEN Form 8300 Activity element in the batch must include a Party element that identifies the batch transmitter. *The batch transmitter should be identical for each FinCEN Form 8300.* There must be one occurrence of this party for each FinCEN Form 8300 Activity in the batch.

#### Transmitter Contact (Required | 1)

This is the official contact for the transmitter. Each FinCEN Form 8300 Activity element in the batch must include a Party element that identifies the point of contact for the batch transmitter. *The transmitter contact should be identical for each FinCEN Form 8300.* There must be one occurrence of this party for each FinCEN Form 8300 Activity in the batch.

#### Individual From Whom The Cash Was Received (Required | 1-99)

This is the individual from whom the cash was received. There must be at least one occurrence (not to exceed 99) of this party for each FinCEN Form 8300 Activity in the batch. This party corresponds with Part I of the FinCEN Form 8300.

#### Person On Whose Behalf This Transaction Was Conducted (Required If Available | 0-99)

This is the person (individual or entity) on whose behalf the transaction was conducted. No more than 99 occurrences of this party type may be recorded for each FinCEN Form 8300 in the batch. This party corresponds with Part II of the FinCEN Form 8300.

#### Business That Received Cash (Required | 1)

This is the business that received the cash associated with the FinCEN Form 8300. There must be one occurrence of this party for each FinCEN Form 8300 Activity in the batch. This party corresponds with Part IV of the FinCEN Form 8300.

#### Authorized Official (Required If Available | 0-1)

This is the title of the official who is authorized to review and approve the transmission of the FinCEN Form 8300. There may only be one occurrence of this party for each FinCEN Form 8300 Activity in the batch. This party corresponds with Part IV (Item 42) of the FinCEN Form 8300.

#### Contact for Assistance (Required If Available | 0-1)



This is the name and telephone number of the person to contact concerning any questions regarding the FinCEN Form 8300. There may only be one occurrence of this party for each FinCEN Form 8300 Activity in the batch. This party corresponds with Part IV (Items 44-45) of the FinCEN Form 8300.

### 2.1.5. CurrencyTransactionActivity

As the container for information about the details of the FinCEN Form 8300, this element identifies information such as the date cash was received, the amount of cash received, and the type of transaction associated with the FinCEN Form 8300. This element must be recorded after the final Party element is recorded for the FinCEN Form 8300. There must only be one occurrence of this element for each FinCEN Form 8300 Activity in the batch. This element corresponds with Part III (Items 28-34) of the FinCEN Form 8300.

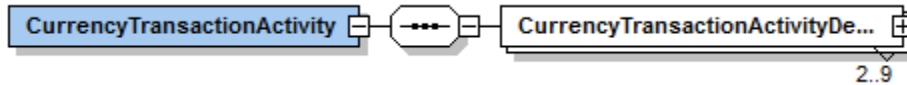

## 3. FinCEN Form 8300 XML Batch Reporting Requirements

This section describes in detail the reporting requirements for each element in the FinCEN Form 8300 batch.

### 3.1. Element Definition Overview

Each element in this user guide is defined using the following terms:

Item	Description
<b>Element Name</b>	This is the name that must be used when recording the element.
<b>minOccurs/maxOccurs</b>	This defines the number of times the element can occur for the parent element. <ul style="list-style-type: none"> <li>• <b>MinOccurs.</b> The minimum number of times this element may be recorded for the parent element (e.g. minOccurs=0 means this element is only required under certain conditions while minOccurs=1 means at least one of the element must be recorded for the parent element in the FinCEN Form 8300.)</li> <li>• <b>MaxOccurs.</b> The maximum number of times this element may be recorded for the parent element (e.g. maxOccurs=99 means this element can occur up to 99 times in the same FinCEN Form 8300.)</li> </ul>
<b>Description</b>	This is the summary description of the element. Included in the description is a list of sub-elements associated with the element (if applicable) as well as any special requirements for when (and when not) to record the element.
<b>Attribute(s)</b>	This specifies the attribute(s) that are required to be recorded for the element. Various elements contain the <b>SeqNum</b> attribute used to identify the associated element in the batch file. The value recorded for this attribute must be numeric and unique.
<b>Parent Element</b>	This identifies the element’s container element. The <Parent> element contains sub elements and is considered a complex element.
<b>Element Restriction(s)</b>	This specifies the requirement level for the element; specifically, under what conditions the element should be recorded. Elements that must be recorded will be label as “Required”, for example “Required. This element must be recorded.” Elements that are required based on certain conditions will indicate the conditions upon which the element must be recorded, for example “Record this element when the party type is associated with the Exempt Party; Otherwise, do not record this element.” NOTE: If neither of the above restrictions are specified for the element, then the element is not required. However, a field that is not required does not mean that it is optional. All fields require an entry when the filer has the relevant data.

Item	Description
<b>Value Restriction(s)</b>	This specifies any requirements and/or restrictions involving the value recorded for the element.
<b>Remarks</b>	This specifies any additional information about the element to assist with reporting; including: <ul style="list-style-type: none"> <li>• Reporting conditions that may result in a batch rejection.</li> <li>• Reporting conditions that may result in a batch accepted with warnings.</li> </ul>
<b>Example</b>	This provides one or more examples of how to record the element. <p>PLEASE BE ADVISED: Most element examples are of scenarios where data is recorded; however, there are valid scenarios where the element may be recorded with a null value or not recorded at all when unknown or not applicable (see examples below):</p> <ul style="list-style-type: none"> <li>• SCENARIO: When NOT to record the element (e.g. "...otherwise, do not record this element.") <i>What this means:</i> The element tag should not be recorded unless the condition described in the Element Restrictions is present.</li> <li>• SCENARIO: When NULL is an acceptable value (e.g. "The value recorded is not equal to Y or is not equal to null.") <i>What this means:</i> The element tag may be recorded without a value and still be considered valid. For example:               <ul style="list-style-type: none"> <li>○ <code>&lt;fc2:MultipleSubjectsIndicator/&gt;</code></li> <li>○ <code>&lt;fc2: MultipleSubjectsIndicator&gt;&lt;/fc2: MultipleSubjectsIndicator&gt;</code></li> </ul> </li> </ul> <p>NOTE: Although the above scenarios are technically valid, it is best practice to omit the element rather than record it with no value.</p>

**IMPORTANT:** FinCEN strongly encourages that filers first test their XML batch files for schema compliance using the schemas available at [www.fincen.gov/base](http://www.fincen.gov/base). Your batch file should pass schema validation before you attempt to submit to FinCEN. Otherwise, it will be at risk of being rejected.

### 3.2. Batch Validation (Form & Fit) Overview

It is important to note that if the batch file does not adhere to the basic format described in this guide in accordance with the FinCEN Form 8300 XML batch schema, then the batch will fail schema validation and will not be accepted by FinCEN.

Here is a list of general schema requirements that your batch must adhere to in addition to the data requirements described for each element throughout this guide. These schema requirements apply to all elements in the batch:

- Element names must include the prefix "fc2" in both the opening tag and closing tag.
- Element names must be spelled correctly and in the correct case. Do NOT include spaces at the beginning or ending of the element names.
- Elements must have a matching closing tag (which includes a self-closing tag in the event that no value is recorded for the element).
- Elements must be in the correct sequence.
- Elements must be recorded when the minOccurs=1 (or greater than 1).
- Elements must not be recorded more than the maxOccurs value for the associated <Parent> element.
- Element values must not exceed the maximum specified character limit.
- Element values must not include leading and/or trailing spaces.
- Element values must not include non-printable characters, such as carriage returns, line feeds, and tabs.

## 4. FinCEN Form 8300 XML Element Requirements

The following defines each element in the FinCEN Form 8300 XML batch in the order in which they can be recorded.

### 4.1. XML declaration/prolog

Element Name:	?xml	minOccurs:	1	maxOccurs:	1						
Description:	XML declaration/prolog. This is the XML declaration which specifies the XML version and character encoding used in the file. The XML declaration must appear on the first line of the file.										
Attribute(s):	The following data must be recorded for XML declaration/prolog:										
	<table border="1"> <thead> <tr> <th>Name</th> <th>Description</th> </tr> </thead> <tbody> <tr> <td>version</td> <td>The version number of the XML. The value recorded must be "1.0"</td> </tr> <tr> <td>encoding</td> <td>The character encoding, which must be UTF-8, used for the XML. The value recorded must be "UTF-8"</td> </tr> </tbody> </table>					Name	Description	version	The version number of the XML. The value recorded must be "1.0"	encoding	The character encoding, which must be UTF-8, used for the XML. The value recorded must be "UTF-8"
Name	Description										
version	The version number of the XML. The value recorded must be "1.0"										
encoding	The character encoding, which must be UTF-8, used for the XML. The value recorded must be "UTF-8"										
Parent Element:	n/a										
Element Restriction(s):	This declaration must be recorded.										
Value Restriction(s):	The value provided must conform to the following requirements: <ul style="list-style-type: none"> <li>&lt;?xml version="1.0" encoding="UTF-8"?&gt;</li> </ul>										
Remarks:	The batch submission will be <u>rejected</u> if any of the following conditions are true: <ul style="list-style-type: none"> <li>The XML declaration/prolog is not recorded with the required values (see Value Restriction(s) above) or it is not recorded on the first line of the batch file.</li> </ul>										
Example:	<?xml version="1.0" encoding="UTF-8"?>										

### 4.2. EFilingBatchXML Elements

Element Name:	EFilingBatchXML	minOccurs:	1	maxOccurs:	1														
Description:	XML batch (header). This is the container for the contents of the batch file. This element is the root element in the FinCEN Form 8300 XML batch file and the container element for all 8300 forms included in the batch. As the root element, it must be the first element recorded in the file, directly following the XML declaration/prolog. The following sub-elements are associated with this element:																		
	<table border="1"> <thead> <tr> <th>Name</th> <th>minOccurs</th> <th>maxOccurs</th> <th>Category</th> </tr> </thead> <tbody> <tr> <td>FormTypeCode</td> <td>1</td> <td>1</td> <td>Simple</td> </tr> <tr> <td>Activity</td> <td>1</td> <td>unbounded</td> <td>Complex</td> </tr> </tbody> </table>					Name	minOccurs	maxOccurs	Category	FormTypeCode	1	1	Simple	Activity	1	unbounded	Complex		
Name	minOccurs	maxOccurs	Category																
FormTypeCode	1	1	Simple																
Activity	1	unbounded	Complex																
Attribute(s)	The following attributes must be recorded for this element:																		
	<table border="1"> <thead> <tr> <th>Name</th> <th>Description</th> </tr> </thead> <tbody> <tr> <td>ActivityCount</td> <td>The count of all &lt;Activity&gt; elements in the batch</td> </tr> <tr> <td>TotalAmount</td> <td>The sum of all &lt;DetailTransactionAmountText&gt; element amounts recorded in the batch</td> </tr> <tr> <td>PartyCount</td> <td>The count of all &lt;Party&gt; elements in the batch where the &lt;ActivityPartyTypeCode&gt; is equal to 16, 23, 4, 3, and 8 (combined)</td> </tr> <tr> <td>xsi:schemaLocation</td> <td>www.fincen.gov/base https://www.fincen.gov/base/EFL_8300XBatchSchema.xsd</td> </tr> <tr> <td>xmlns:xsi</td> <td>http://www.w3.org/2001/XMLSchema-instance</td> </tr> <tr> <td>xmlns:fc2</td> <td>www.fincen.gov/base</td> </tr> </tbody> </table> <p><i>NOTE: All attributes must be present, but their order is not important.</i></p>					Name	Description	ActivityCount	The count of all <Activity> elements in the batch	TotalAmount	The sum of all <DetailTransactionAmountText> element amounts recorded in the batch	PartyCount	The count of all <Party> elements in the batch where the <ActivityPartyTypeCode> is equal to 16, 23, 4, 3, and 8 (combined)	xsi:schemaLocation	www.fincen.gov/base https://www.fincen.gov/base/EFL_8300XBatchSchema.xsd	xmlns:xsi	http://www.w3.org/2001/XMLSchema-instance	xmlns:fc2	www.fincen.gov/base
Name	Description																		
ActivityCount	The count of all <Activity> elements in the batch																		
TotalAmount	The sum of all <DetailTransactionAmountText> element amounts recorded in the batch																		
PartyCount	The count of all <Party> elements in the batch where the <ActivityPartyTypeCode> is equal to 16, 23, 4, 3, and 8 (combined)																		
xsi:schemaLocation	www.fincen.gov/base https://www.fincen.gov/base/EFL_8300XBatchSchema.xsd																		
xmlns:xsi	http://www.w3.org/2001/XMLSchema-instance																		
xmlns:fc2	www.fincen.gov/base																		
Parent Element:	n/a																		
Element Restriction(s):	Required. This element must be recorded.																		

Element Name:	EfilingBatchXML	minOccurs:	1	maxOccurs:	1
Value Restriction(s):	n/a				
Remarks:	The batch submission will be <b>rejected</b> if any of the following conditions are true: <ul style="list-style-type: none"> <li>The element is not recorded.</li> <li>One or more of the attributes are missing, incorrectly formatted, or contain an invalid value.</li> <li>The reported attribute count does not match the actual count.</li> </ul>				
Example:	<pre>&lt;?xml version="1.0" encoding="UTF-8"?&gt; &lt;fc2:EfilingBatchXML TotalAmount="25000" PartyCount="4" ActivityCount="1" xsi:schemaLocation="www.fincen.gov/base https://www.fincen.gov/base https://www.fincen.gov/base/EFL_8300XBatchSchema.xsd" xmlns:xsi="http://www.w3.org/2001/XMLSchema-instance" xmlns:fc2="www.fincen.gov/base"&gt;   &lt;fc2:FormTypeCode&gt;8300X&lt;/fc2:FormTypeCode&gt;   &lt;fc2:Activity SeqNum="1"&gt;</pre>				

Element Name:	FormTypeCode	minOccurs:	1	maxOccurs:	1
Description:	Form type (code). This element identifies the type of form being reported in the batch.				
Attribute(s)	n/a				
Parent Element:	EfilingBatchXML				
Element Restriction(s):	Required. This element must be recorded.				
Value Restriction(s):	The value provided must equal: 8300X				
Remarks:	The batch submission will be <b>rejected</b> if any of the following conditions are true: <ul style="list-style-type: none"> <li>The element is not recorded.</li> <li>The value is null or not equal to 8300X.</li> </ul>				
Example:	<fc2:FormTypeCode>8300X</fc2:FormTypeCode>				

Element Name:	Activity	See <i>Activity Elements</i> for details.
---------------	----------	---

### 4.3. Activity Elements

Element Name:	Activity	minOccurs:	1	maxOccurs:	unbounded																																								
Description:	Activity (header). This is the container for all information related to the FinCEN Form 8300. The first <Activity> element in the batch file must directly follow the <FormTypeCode> element. The batch must contain at least one occurrence of this element. There is no maximum occurrence value set for this element; however, the total size of the batch file must not exceed 60MB. The following sub-elements are associated with this element:																																												
	<table border="1"> <thead> <tr> <th>Name</th> <th>minOccurs</th> <th>maxOccurs</th> <th>Category</th> </tr> </thead> <tbody> <tr> <td>EfilingPriorDocumentNumber (BSA ID)</td> <td>0</td> <td>1</td> <td>Simple</td> </tr> <tr> <td>FilingDateText (Item 43)</td> <td>1</td> <td>1</td> <td>Simple</td> </tr> <tr> <td>MultipleSubjectsIndicator (Item 2)</td> <td>0</td> <td>1</td> <td>Simple</td> </tr> <tr> <td>SuspiciousTransactionIndicator (Item 1b)</td> <td>0</td> <td>1</td> <td>Simple</td> </tr> <tr> <td>TransactionOnBehalfMultiplePersonsIndicator (Item 15)</td> <td>0</td> <td>1</td> <td>Simple</td> </tr> <tr> <td>ActivityAssociation (Item 1 - New/Amends prior report)</td> <td>1</td> <td>1</td> <td>Complex</td> </tr> <tr> <td>Party (Part I, II, IV, 42, 44-45, Transmitter/trans. contact)</td> <td>4</td> <td>203</td> <td>Complex</td> </tr> <tr> <td>CurrencyTransactionActivity (Part III)</td> <td>1</td> <td>1</td> <td>Complex</td> </tr> <tr> <td>ActivityNarrativeInformation (Comments)</td> <td>0</td> <td>1</td> <td>Complex</td> </tr> </tbody> </table>					Name	minOccurs	maxOccurs	Category	EfilingPriorDocumentNumber (BSA ID)	0	1	Simple	FilingDateText (Item 43)	1	1	Simple	MultipleSubjectsIndicator (Item 2)	0	1	Simple	SuspiciousTransactionIndicator (Item 1b)	0	1	Simple	TransactionOnBehalfMultiplePersonsIndicator (Item 15)	0	1	Simple	ActivityAssociation (Item 1 - New/Amends prior report)	1	1	Complex	Party (Part I, II, IV, 42, 44-45, Transmitter/trans. contact)	4	203	Complex	CurrencyTransactionActivity (Part III)	1	1	Complex	ActivityNarrativeInformation (Comments)	0	1	Complex
Name	minOccurs	maxOccurs	Category																																										
EfilingPriorDocumentNumber (BSA ID)	0	1	Simple																																										
FilingDateText (Item 43)	1	1	Simple																																										
MultipleSubjectsIndicator (Item 2)	0	1	Simple																																										
SuspiciousTransactionIndicator (Item 1b)	0	1	Simple																																										
TransactionOnBehalfMultiplePersonsIndicator (Item 15)	0	1	Simple																																										
ActivityAssociation (Item 1 - New/Amends prior report)	1	1	Complex																																										
Party (Part I, II, IV, 42, 44-45, Transmitter/trans. contact)	4	203	Complex																																										
CurrencyTransactionActivity (Part III)	1	1	Complex																																										
ActivityNarrativeInformation (Comments)	0	1	Complex																																										
Attribute(s)	The following attributes must be recorded for this element:																																												
	<table border="1"> <thead> <tr> <th>Name</th> <th>Description</th> </tr> </thead> <tbody> </tbody> </table>					Name	Description																																						
Name	Description																																												

Element Name:	Activity	minOccurs:	1	maxOccurs:	unbounded
	SeqNum	The value recorded for this attribute must be numeric and unique. It may contain any numeric value up to 19 characters in length.			
Parent Element:	EFilingBatchXML				
Element Restriction(s):	Required. This element must be recorded.				
Value Restriction(s):	n/a				
Remarks:	<p>The batch submission will be <u>rejected</u> if any of the following conditions are true:</p> <ul style="list-style-type: none"> <li>• The element is not recorded.</li> <li>• The element is missing a "SeqNum" attribute.</li> <li>• The element contains a "SeqNum" attribute with a duplicate or invalid value.</li> <li>• The element is self-closing (i.e. no sub-elements are recorded)</li> </ul>				
Example:	<pre>&lt;fc2:Activity SeqNum="1"&gt;   &lt;fc2:EFilingPriorDocumentNumber&gt;31000000001234&lt;/fc2:EFilingPriorDocumentNumber&gt;   &lt;fc2:FilingDateText&gt;20180920&lt;/fc2:FilingDateText&gt;   &lt;fc2:MultipleSubjectsIndicator&gt;Y&lt;/fc2:MultipleSubjectsIndicator&gt;   &lt;fc2:SuspiciousTransactionIndicator&gt;Y&lt;/fc2:SuspiciousTransactionIndicator&gt;   &lt;fc2:TransactionOnBehalfMultiplePersonsIndicator&gt;Y&lt;/fc2:TransactionOnBehalfMultiplePersonsIndicator&gt;   &lt;fc2:ActivityAssociation SeqNum="2"&gt;</pre>				

Element Name:	EFilingPriorDocumentNumber	minOccurs:	0	maxOccurs:	1
Description:	<p>Prior report BSA Identifier (number). This element identifies the BSA Identifier (BSA ID) of the previously-filed FinCEN Form 8300 when filing a correction/amendment. This element corresponds with the following item(s):</p> <ul style="list-style-type: none"> <li>• Prior form BSA Identifier (BSA ID)</li> </ul> <p><i>Please refer to Attachment C General Instruction 13 "Amended Reports" and to Header Page instructions for additional information regarding the above item(s).</i></p>				
Attribute(s)	n/a				
Parent Element:	Activity				
Element Restriction(s):	Record this element when the FinCEN Form 8300 being filed corrects/amends a prior form; otherwise, do not record this element.				
Value Restriction(s):	The value provided must conform to the following requirements: 14-digit numeric BSA ID (if known); 14 consecutive zeros, i.e. "00000000000000" (if the BSA ID is unknown).				
Remarks:	<p>The batch submission will be rejected if any of the following conditions are true:</p> <ul style="list-style-type: none"> <li>• The element is recorded but without a value (i.e. the value is null).</li> <li>• The value recorded contains non-numeric characters.</li> <li>• The value recorded is not a valid BSA Identifier, or not 14 zeros (0) when the prior FinCEN Form 8300 BSA Identifier is unknown.</li> </ul> <p>The batch submission will be <u>accepted with warning</u> if any of the following conditions are true:</p> <ul style="list-style-type: none"> <li>• The element is not recorded and CorrectsAmendsPriorReportIndicator contains a Y value.</li> <li>• The element is recorded with a valid value and InitialReportIndicator contains a Y value.</li> </ul>				
Example:	<fc2:EFilingPriorDocumentNumber>31000000000001</fc2:EFilingPriorDocumentNumber>				

Element Name:	FilingDateText	minOccurs:	1	maxOccurs:	1
Description:	<p>Date of signature (date). This element identifies the date in which the FinCEN Form 8300 is signed and filed electronically through FinCEN's BSA E-Filing System. This element corresponds with the following item(s):</p> <ul style="list-style-type: none"> <li>• 43. Date of signature</li> </ul>				
Attribute(s)	n/a				

Element Name:	FilingDateText	minOccurs:	1	maxOccurs:	1
Parent Element:	Activity				
Element Restriction(s):	Required. This element must be recorded.				
Value Restriction(s):	The value provided must conform to the following requirements: 8 numeric characters in the format YYYYMMDD where YYYY = year, MM = month, and DD = day. Single digit days or months must be prefaced by a zero.				
Remarks:	<p>The batch submission will be <b>rejected</b> if any of the following conditions are true:</p> <ul style="list-style-type: none"> <li>The element is not recorded.</li> <li>The element is recorded but without a value (i.e. the value is null).</li> <li>The value recorded for the element is not a valid date in the format YYYYMMDD.</li> </ul> <p>The batch submission will be <b>accepted with warning</b> if any of the following conditions are true:</p> <ul style="list-style-type: none"> <li>The value recorded is a date greater than the current date or less than January 1, 2000.</li> </ul>				
Example:	<fc2:FilingDateText>20181101</fc2:FilingDateText>				

Element Name:	MultipleSubjectsIndicator	minOccurs:	0	maxOccurs:	1
Description:	Multiple individuals from whom cash was received (indicator). This element allows the filer to indicate that there are multiple individuals who conducted the transaction. This element corresponds with the following item(s):				
	<ul style="list-style-type: none"> <li>2. Multiple Part I</li> </ul>				
Attribute(s)	n/a				
Parent Element:	Activity				
Element Restriction(s):	Record this element when the FinCEN Form 8300 being filed involves multiple individuals from whom cash was received and at least one additional Part I individual is recorded; otherwise, do not record this element.				
Value Restriction(s):	The value provided must conform to the following requirements: Must equal Y				
Remarks:	<p>The batch submission will be <b>rejected</b> if any of the following conditions are true:</p> <ul style="list-style-type: none"> <li>The element is not null and contains a value not equal to "Y"</li> </ul> <p>The batch submission will be <b>accepted with warning</b> if any of the following conditions are true:</p> <ul style="list-style-type: none"> <li>The element is recorded with a Y value but there is only one party recorded associated with the individual from whom cash was received.</li> <li>The element is not recorded with a Y value and there is more than one party recorded associated with the individual from whom cash was received.</li> </ul>				
Example:	<fc2:MultipleSubjectsIndicator>Y</fc2:MultipleSubjectsIndicator>				

Element Name:	SuspiciousTransactionIndicator	minOccurs:	0	maxOccurs:	1
Description:	Suspicious transaction (indicator). This element allows the filer to voluntarily report that the FinCEN Form 8300 involves a suspicious transaction in which it appears that a person is attempting to cause Form 8300 not to be filed, is attempting to cause a false or incomplete Form 8300 to be filed, or is involved in possible illegal activity. This element corresponds with the following item(s):				
	<ul style="list-style-type: none"> <li>1b. Suspicious transaction</li> </ul> <p><i>Please refer to Attachment C General Instruction 10 "Definitions" and Item 1 instructions for additional information regarding the above item(s).</i></p>				
Attribute(s)	n/a				
Parent Element:	Activity				
Element Restriction(s):	Record this element when the FinCEN Form 8300 being filed involves a suspicious transaction; otherwise, do not record this element.				
Value Restriction(s):	The value provided must conform to the following requirements: Must equal Y				
Remarks:	<p>The batch submission will be <b>rejected</b> if any of the following conditions are true:</p> <ul style="list-style-type: none"> <li>The element is not null and contains a value not equal to "Y"</li> </ul>				
Example:	<fc2:SuspiciousTransactionIndicator>Y</fc2:SuspiciousTransactionIndicator>				

Element Name:	TransactionOnBehalfMultiplePersonsIndicator	minOccurs:	0	maxOccurs:	1
Description:	Multiple persons on whose behalf this transaction was conducted (indicator). This element allows the filer to indicate that there are multiple persons on whose behalf this transaction was conducted. This element corresponds with the following item(s): <ul style="list-style-type: none"> <li>15. Multiple Part II</li> </ul>				
Attribute(s)	n/a				
Parent Element:	Activity				
Element Restriction(s):	Record this element when the FinCEN Form 8300 being filed involves persons on whose behalf this transaction was conducted and at least one additional Part II person is recorded; otherwise, do not record this element.				
Value Restriction(s):	The value provided must conform to the following requirements: Must equal Y				
Remarks:	The batch submission will be <u>rejected</u> if any of the following conditions are true: <ul style="list-style-type: none"> <li>The element is not null and contains a value not equal to "Y"</li> </ul> The batch submission will be <u>accepted with warning</u> if any of the following conditions are true: <ul style="list-style-type: none"> <li>The element is recorded with a Y value but only one (or no) party associated with the person on whose behalf this transaction was conducted is recorded.</li> <li>The element is not recorded with a Y value and there is more than one party associated with the person on whose behalf this transaction was conducted.</li> </ul>				
Example:	<TransactionOnBehalfMultiplePersonsIndicator>Y</TransactionOnBehalfMultiplePersonsIndicator>				

Element Name:	ActivityAssociation	See <i>ActivityAssociation Elements</i> for details.
---------------	---------------------	--

Element Name:	Party	See <i>Party Elements</i> for details.
---------------	-------	--

Element Name:	CurrencyTransactionActivity	See <i>AssetsAttribute Elements</i> for details.
---------------	-----------------------------	--

Element Name:	ActivityNarrativeInformation	See <i>ActivityNarrativeInformation Elements</i> for details.
---------------	------------------------------	---

#### 4.4. ActivityAssociation Elements

Element Name:	ActivityAssociation	minOccurs:	1	maxOccurs:	1												
Description:	Type of filing (header). This element is the container for information about the type of filing associated with the FinCEN Form 8300. The following sub-elements are associated with this element: <table border="1" data-bbox="443 1467 1385 1581"> <thead> <tr> <th>Name</th> <th>minOccurs</th> <th>maxOccurs</th> <th>Category</th> </tr> </thead> <tbody> <tr> <td>CorrectsAmendsPriorReportIndicator</td> <td>0</td> <td>1</td> <td>Simple</td> </tr> <tr> <td>InitialReportIndicator</td> <td>0</td> <td>1</td> <td>Simple</td> </tr> </tbody> </table> <i>*Only one of the above sub-elements should be recorded.</i> <p>This element corresponds with the following item(s):</p> <ul style="list-style-type: none"> <li>1. Type of filing – New                             <ul style="list-style-type: none"> <li>1a. Amends prior report</li> </ul> </li> </ul> Please refer to Attachment C General Instruction 13 "Amended Reports" and to Header Page instructions for additional information regarding the above items.					Name	minOccurs	maxOccurs	Category	CorrectsAmendsPriorReportIndicator	0	1	Simple	InitialReportIndicator	0	1	Simple
Name	minOccurs	maxOccurs	Category														
CorrectsAmendsPriorReportIndicator	0	1	Simple														
InitialReportIndicator	0	1	Simple														
Attribute(s)	The following attributes must be recorded for this element: <table border="1" data-bbox="443 1833 1385 1875"> <thead> <tr> <th>Name</th> <th>Description</th> </tr> </thead> <tbody> <tr> <td></td> <td></td> </tr> </tbody> </table>					Name	Description										
Name	Description																

Element Name:	ActivityAssociation	minOccurs:	1	maxOccurs:	1
	SeqNum	The value recorded for this attribute must be numeric and unique. It may contain any numeric value up to 19 characters in length.			
Parent Element:	Activity				
Element Restriction(s):	Required. This element must be recorded.				
Value Restriction(s):	n/a				
Remarks:	<p>The batch submission will be <u>rejected</u> if any of the following conditions are true:</p> <ul style="list-style-type: none"> <li>• The element is not recorded.</li> <li>• The element is missing a "SeqNum" attribute.</li> <li>• The element contains a "SeqNum" attribute with a duplicate or invalid value.</li> <li>• The element is recorded but neither of the following sub-elements are recorded: <ul style="list-style-type: none"> <li>○ &lt;CorrectsAmendsPriorReportIndicator&gt;</li> <li>○ &lt;InitialReportIndicator&gt;</li> </ul> </li> </ul> <p>The batch submission will be <u>accepted with warning</u> if any of the following conditions are true:</p> <ul style="list-style-type: none"> <li>• Both of the following sub-elements are recorded with a null value: <ul style="list-style-type: none"> <li>○ &lt;CorrectsAmendsPriorReportIndicator&gt;</li> <li>○ &lt;InitialReportIndicator&gt;</li> </ul> </li> <li>• Both of the following sub-elements are recorded with a Y value: <ul style="list-style-type: none"> <li>○ &lt;CorrectsAmendsPriorReportIndicator&gt;</li> <li>○ &lt;InitialReportIndicator&gt;</li> </ul> </li> </ul>				
Example:	<p>When filing an initial (new) FinCEN Form 8300:  &lt;fc2:ActivityAssociation SeqNum="2"&gt;      &lt;fc2:InitialReportIndicator&gt;Y&lt;/fc2:InitialReportIndicator&gt;  &lt;/fc2:ActivityAssociation&gt;</p> <p>When filing an amendment to a previously filed FinCEN Form 8300:  &lt;fc2:ActivityAssociation SeqNum="2"&gt;      &lt;fc2:CorrectsAmendsPriorReportIndicator&gt;Y&lt;/fc2:CorrectsAmendsPriorReportIndicator&gt;  &lt;/fc2:ActivityAssociation&gt;</p>				

Element Name:	CorrectsAmendsPriorReportIndicator	minOccurs:	0	maxOccurs:	1
Description:	Amends prior report (indicator). This element declares that the FinCEN Form 8300 being filed amends a previously filed FinCEN Form 8300. This element corresponds with the following item(s): <ul style="list-style-type: none"> <li>• 1a. Amends prior report</li> </ul> <i>Please refer to Attachment C General Instruction 13 "Amended Reports" and to Header Page instructions for additional information regarding this item.</i>				
Attribute(s)	n/a				
Parent Element:	ActivityAssociation				
Element Restriction(s):	Record this element when the FinCEN Form 8300 being filed amends a previously filed FinCEN Form 8300; otherwise, do not record this element but instead record the InitialReportIndicator element with a Y value. If this element is recorded, the following element must also be recorded with a valid value: <ul style="list-style-type: none"> <li>• &lt;EFilingPriorDocumentNumber&gt;</li> </ul>				
Value Restriction(s):	The value provided must conform to the following requirements: Must equal Y				
Remarks:	The batch submission will be <u>rejected</u> if any of the following conditions are true: <ul style="list-style-type: none"> <li>• The element is not null and contains a value not equal to "Y"</li> </ul>				
Example:	<fc2:CorrectsAmendsPriorReportIndicator>Y</fc2:CorrectsAmendsPriorReportIndicator>				



Element Name:	InitialReportIndicator	minOccurs:	0	maxOccurs:	1
Description:	Initial report (indicator). This element declares that the FinCEN Form 8300 being filed is the first report filed on the FinCEN Form 8300. This element corresponds with the following item(s): <ul style="list-style-type: none"> <li>1. Type of filing – New</li> </ul> Please refer to Attachment C Header Page instructions for additional information regarding this item.				
Attribute(s)	n/a				
Parent Element:	ActivityAssociation				
Element Restriction(s):	Record this element when the FinCEN Form 8300 being filed is the first report filed on the transaction activity or related transaction activity; otherwise, do not record this element but instead record the CorrectsAmendsPriorReportIndicator element with a Y value.				
Value Restriction(s):	The value provided must conform to the following requirements: Must equal Y				
Remarks:	The batch submission will be <u>rejected</u> if any of the following conditions are true: <ul style="list-style-type: none"> <li>The element is not null and contains a value not equal to "Y"</li> </ul>				
Example:	<fc2:InitialReportIndicator>Y</fc2:InitialReportIndicator>				

### 4.5. Party Elements

Element Name:	Party	minOccurs:	4	maxOccurs:	203																								
Description:	Party (header). This is the container for information about the individual or entity associated with the FinCEN Form 8300; specifically: <ul style="list-style-type: none"> <li>Transmitter (required, one only).</li> <li>Transmitter contact (required, one only).</li> <li>The individual from whom the cash was received (required, multiples permitted up to 99).</li> <li>The person on whose behalf this transaction was conducted (required if available, multiples permitted up to 99).</li> <li>The business that received cash (required, one only).</li> <li>The authorized official (required if available, one only).</li> <li>The person to contact for assistance (required if available, one only).</li> </ul> The following tables describe all possible sub-elements for each party type at the activity level:																												
<b>Activity party type code definitions</b> 35 = Transmitter   37 = Transmitter Contact   3 = Authorized Official 8 = Contact for Assistance   16 = Individual from whom the cash was received 23 = Person on whose behalf transaction conducted   4 = Business that received cash																													
1. Transmitter Information (Required   Batch Transmitter Information   1 occurrence)																													
<table border="1"> <thead> <tr> <th>Name</th> <th>minOccurs</th> <th>maxOccurs</th> <th>Content</th> </tr> </thead> <tbody> <tr> <td>ActivityPartyTypeCode (Code 35)</td> <td>1</td> <td>1</td> <td>Simple</td> </tr> <tr> <td>PartyName</td> <td>1</td> <td>1</td> <td>Complex</td> </tr> <tr> <td>Address</td> <td>1</td> <td>1</td> <td>Complex</td> </tr> <tr> <td>PhoneNumber</td> <td>1</td> <td>1</td> <td>Complex</td> </tr> <tr> <td>PartyIdentification</td> <td>1</td> <td>1</td> <td>Complex</td> </tr> </tbody> </table>						Name	minOccurs	maxOccurs	Content	ActivityPartyTypeCode (Code 35)	1	1	Simple	PartyName	1	1	Complex	Address	1	1	Complex	PhoneNumber	1	1	Complex	PartyIdentification	1	1	Complex
Name	minOccurs	maxOccurs	Content																										
ActivityPartyTypeCode (Code 35)	1	1	Simple																										
PartyName	1	1	Complex																										
Address	1	1	Complex																										
PhoneNumber	1	1	Complex																										
PartyIdentification	1	1	Complex																										
2. Transmitter Contact Information (Required   Batch Transmitter Information   1 occurrence)																													
<table border="1"> <thead> <tr> <th>Name</th> <th>minOccurs</th> <th>maxOccurs</th> <th>Content</th> </tr> </thead> <tbody> <tr> <td>ActivityPartyTypeCode (Code 37)</td> <td>1</td> <td>1</td> <td>Simple</td> </tr> <tr> <td>PartyName</td> <td>1</td> <td>1</td> <td>Complex</td> </tr> </tbody> </table>						Name	minOccurs	maxOccurs	Content	ActivityPartyTypeCode (Code 37)	1	1	Simple	PartyName	1	1	Complex												
Name	minOccurs	maxOccurs	Content																										
ActivityPartyTypeCode (Code 37)	1	1	Simple																										
PartyName	1	1	Complex																										
3. Individual from whom the cash was received (Required   Part I, Items 3-14   1-99 occurrences)																													

Element Name:	Party	minOccurs:	4	maxOccurs:	203																																																																																																												
	<table border="1"> <thead> <tr> <th>Name</th> <th>minOccurs</th> <th>maxOccurs</th> <th>Content</th> </tr> </thead> <tbody> <tr> <td>ActivityPartyTypeCode (Code 16)</td> <td>1</td> <td>1</td> <td>Simple</td> </tr> <tr> <td>IndividualBirthDateText (Item 8)</td> <td>0</td> <td>1</td> <td>Simple</td> </tr> <tr> <td>PartyName (Items 3-5)</td> <td>1</td> <td>1</td> <td>Complex</td> </tr> <tr> <td>Address (Items 7, 9-12)</td> <td>1</td> <td>1</td> <td>Complex</td> </tr> <tr> <td>PartyIdentification (Items 16, 14)</td> <td>1</td> <td>2</td> <td>Complex</td> </tr> <tr> <td>PartyOccupationBusiness (Item 13)</td> <td>0</td> <td>1</td> <td>Complex</td> </tr> </tbody> </table> <p>4. Person on whose behalf transaction conducted (Required if available   Part II, Items 16-27   0-99 occurrences)</p> <table border="1"> <thead> <tr> <th>Name</th> <th>minOccurs</th> <th>maxOccurs</th> <th>Content</th> </tr> </thead> <tbody> <tr> <td>ActivityPartyTypeCode (Code 16)</td> <td>1</td> <td>1</td> <td>Simple</td> </tr> <tr> <td>PartyTypeCode</td> <td>1</td> <td>1</td> <td>Simple</td> </tr> <tr> <td>PartyName (Items 16-18, 20)</td> <td>0</td> <td>2</td> <td>Complex</td> </tr> <tr> <td>Address (Items 21, 23-26)</td> <td>0</td> <td>1</td> <td>Complex</td> </tr> <tr> <td>PartyIdentification (Items 19, 27)</td> <td>0</td> <td>3</td> <td>Complex</td> </tr> <tr> <td>PartyOccupationBusiness (Item 22)</td> <td>0</td> <td>1</td> <td>Complex</td> </tr> </tbody> </table> <p>5. Business that received cash (Required   Part IV, Items 35-41   1 occurrence)</p> <table border="1"> <thead> <tr> <th>Name</th> <th>minOccurs</th> <th>maxOccurs</th> <th>Content</th> </tr> </thead> <tbody> <tr> <td>ActivityPartyTypeCode (Code 4)</td> <td>1</td> <td>1</td> <td>Simple</td> </tr> <tr> <td>PartyName (Item 35)</td> <td>1</td> <td>1</td> <td>Complex</td> </tr> <tr> <td>Address (Items 37-40)</td> <td>0</td> <td>1</td> <td>Complex</td> </tr> <tr> <td>PartyIdentification (Item 36)</td> <td>1</td> <td>2</td> <td>Complex</td> </tr> <tr> <td>PartyOccupationBusiness (Item 41)</td> <td>0</td> <td>1</td> <td>Complex</td> </tr> </tbody> </table> <p>6. Authorized official (Required if available   Part IV, Item 42 Title   0-1 occurrence)</p> <table border="1"> <thead> <tr> <th>Name</th> <th>minOccurs</th> <th>maxOccurs</th> <th>Content</th> </tr> </thead> <tbody> <tr> <td>ActivityPartyTypeCode (Code 3)</td> <td>1</td> <td>1</td> <td>Simple</td> </tr> <tr> <td>PartyName (Item 42 Title)</td> <td>1</td> <td>1</td> <td>Complex</td> </tr> </tbody> </table> <p>7. Contact for assistance (Required if available   Part IV, Items 44-45   0-1 occurrence)</p> <table border="1"> <thead> <tr> <th>Name</th> <th>minOccurs</th> <th>maxOccurs</th> <th>Content</th> </tr> </thead> <tbody> <tr> <td>ActivityPartyTypeCode (Code 8)</td> <td>1</td> <td>1</td> <td>Simple</td> </tr> <tr> <td>PartyName (Item 44)*</td> <td>0</td> <td>1</td> <td>Complex</td> </tr> <tr> <td>PhoneNumber (Item 45)*</td> <td>0</td> <td>1</td> <td>Complex</td> </tr> </tbody> </table> <p><i>*If the Contact for assistance party type is recorded, then the PartyName and/or PhoneNumber data must be provided in addition to the ActivityPartyTypeCode.</i></p>					Name	minOccurs	maxOccurs	Content	ActivityPartyTypeCode (Code 16)	1	1	Simple	IndividualBirthDateText (Item 8)	0	1	Simple	PartyName (Items 3-5)	1	1	Complex	Address (Items 7, 9-12)	1	1	Complex	PartyIdentification (Items 16, 14)	1	2	Complex	PartyOccupationBusiness (Item 13)	0	1	Complex	Name	minOccurs	maxOccurs	Content	ActivityPartyTypeCode (Code 16)	1	1	Simple	PartyTypeCode	1	1	Simple	PartyName (Items 16-18, 20)	0	2	Complex	Address (Items 21, 23-26)	0	1	Complex	PartyIdentification (Items 19, 27)	0	3	Complex	PartyOccupationBusiness (Item 22)	0	1	Complex	Name	minOccurs	maxOccurs	Content	ActivityPartyTypeCode (Code 4)	1	1	Simple	PartyName (Item 35)	1	1	Complex	Address (Items 37-40)	0	1	Complex	PartyIdentification (Item 36)	1	2	Complex	PartyOccupationBusiness (Item 41)	0	1	Complex	Name	minOccurs	maxOccurs	Content	ActivityPartyTypeCode (Code 3)	1	1	Simple	PartyName (Item 42 Title)	1	1	Complex	Name	minOccurs	maxOccurs	Content	ActivityPartyTypeCode (Code 8)	1	1	Simple	PartyName (Item 44)*	0	1	Complex	PhoneNumber (Item 45)*	0	1	Complex
Name	minOccurs	maxOccurs	Content																																																																																																														
ActivityPartyTypeCode (Code 16)	1	1	Simple																																																																																																														
IndividualBirthDateText (Item 8)	0	1	Simple																																																																																																														
PartyName (Items 3-5)	1	1	Complex																																																																																																														
Address (Items 7, 9-12)	1	1	Complex																																																																																																														
PartyIdentification (Items 16, 14)	1	2	Complex																																																																																																														
PartyOccupationBusiness (Item 13)	0	1	Complex																																																																																																														
Name	minOccurs	maxOccurs	Content																																																																																																														
ActivityPartyTypeCode (Code 16)	1	1	Simple																																																																																																														
PartyTypeCode	1	1	Simple																																																																																																														
PartyName (Items 16-18, 20)	0	2	Complex																																																																																																														
Address (Items 21, 23-26)	0	1	Complex																																																																																																														
PartyIdentification (Items 19, 27)	0	3	Complex																																																																																																														
PartyOccupationBusiness (Item 22)	0	1	Complex																																																																																																														
Name	minOccurs	maxOccurs	Content																																																																																																														
ActivityPartyTypeCode (Code 4)	1	1	Simple																																																																																																														
PartyName (Item 35)	1	1	Complex																																																																																																														
Address (Items 37-40)	0	1	Complex																																																																																																														
PartyIdentification (Item 36)	1	2	Complex																																																																																																														
PartyOccupationBusiness (Item 41)	0	1	Complex																																																																																																														
Name	minOccurs	maxOccurs	Content																																																																																																														
ActivityPartyTypeCode (Code 3)	1	1	Simple																																																																																																														
PartyName (Item 42 Title)	1	1	Complex																																																																																																														
Name	minOccurs	maxOccurs	Content																																																																																																														
ActivityPartyTypeCode (Code 8)	1	1	Simple																																																																																																														
PartyName (Item 44)*	0	1	Complex																																																																																																														
PhoneNumber (Item 45)*	0	1	Complex																																																																																																														
Attribute(s)	<p>The following attributes must be recorded for this element:</p> <table border="1"> <thead> <tr> <th>Name</th> <th>Description</th> </tr> </thead> <tbody> <tr> <td>SeqNum</td> <td>The value recorded for this attribute must be numeric and unique. It may contain any numeric value up to 19 characters in length.</td> </tr> </tbody> </table>					Name	Description	SeqNum	The value recorded for this attribute must be numeric and unique. It may contain any numeric value up to 19 characters in length.																																																																																																								
Name	Description																																																																																																																
SeqNum	The value recorded for this attribute must be numeric and unique. It may contain any numeric value up to 19 characters in length.																																																																																																																
Parent Element:	Activity																																																																																																																

Element Name:	Party	minOccurs:	4	maxOccurs:	203																											
Element Restriction(s):	Required. This element must be recorded.  The following table describes the minimum and maximum reporting requirements per FinCEN Form 8300 document by party type (at the activity level): <table border="1" style="margin-left: 20px;"> <thead> <tr> <th>Party type</th> <th>minOccurs</th> <th>maxOccurs</th> </tr> </thead> <tbody> <tr> <td>Transmitter</td> <td>1</td> <td>1</td> </tr> <tr> <td>Transmitter contact</td> <td>1</td> <td>1</td> </tr> <tr> <td>Individual from whom the cash was received</td> <td>1</td> <td>99</td> </tr> <tr> <td>Person on whose behalf transaction conducted</td> <td>0</td> <td>99</td> </tr> <tr> <td>Business that received cash</td> <td>1</td> <td>1</td> </tr> <tr> <td>Authorized official</td> <td>0</td> <td>1</td> </tr> <tr> <td>Contact for assistance</td> <td>0</td> <td>1</td> </tr> <tr> <td style="text-align: right;"><i>Total (per document)</i></td> <td>4</td> <td>203</td> </tr> </tbody> </table>					Party type	minOccurs	maxOccurs	Transmitter	1	1	Transmitter contact	1	1	Individual from whom the cash was received	1	99	Person on whose behalf transaction conducted	0	99	Business that received cash	1	1	Authorized official	0	1	Contact for assistance	0	1	<i>Total (per document)</i>	4	203
Party type	minOccurs	maxOccurs																														
Transmitter	1	1																														
Transmitter contact	1	1																														
Individual from whom the cash was received	1	99																														
Person on whose behalf transaction conducted	0	99																														
Business that received cash	1	1																														
Authorized official	0	1																														
Contact for assistance	0	1																														
<i>Total (per document)</i>	4	203																														
Value Restriction(s):	n/a																															
Remarks:	The batch submission will be <u>rejected</u> if any of the following conditions are true: <ul style="list-style-type: none"> <li>• The minimum number of party elements are not recorded or are incorrectly formatted.</li> <li>• The element is missing a "SeqNum" attribute.</li> <li>• The element contains a "SeqNum" attribute with a duplicate or invalid value.</li> <li>• The following party types are not recorded or exceed the maximum occurrence for the FinCEN Form 8300:                         <ul style="list-style-type: none"> <li>○ Transmitter (1 occurrence)</li> <li>○ Transmitter contact (1 occurrence)</li> <li>○ Individual from whom the cash was received (at least 1 occurrence)</li> <li>○ Business that received cash (1 occurrence)</li> </ul> </li> <li>• More than the maximum occurrence of a particular party type is recorded.</li> </ul>																															
Example:	See 5. Party Elements by Party Type for detailed examples of each party type.																															

Element Name:	ActivityPartyTypeCode	minOccurs:	1	maxOccurs:	1																
Description:	Activity party type (code). This element identifies the type of party associated with the FinCEN Form 8300.																				
Attribute(s)	n/a																				
Parent Element:	Party																				
Element Restriction(s):	Required. Each Party element must include this element (ActivityPartyTypeCode) with a valid code.																				
Value Restriction(s):	The value provided must conform to the following requirements: <table border="1" style="margin-left: 20px;"> <thead> <tr> <th>Code</th> <th>Description</th> </tr> </thead> <tbody> <tr> <td>35</td> <td>Transmitter</td> </tr> <tr> <td>37</td> <td>Transmitter contact</td> </tr> <tr> <td>16</td> <td>Individual from whom the cash was received</td> </tr> <tr> <td>23</td> <td>Person on whose behalf transaction conducted</td> </tr> <tr> <td>4</td> <td>Business that received cash</td> </tr> <tr> <td>3</td> <td>Authorized official</td> </tr> <tr> <td>8</td> <td>Contact for assistance</td> </tr> </tbody> </table>					Code	Description	35	Transmitter	37	Transmitter contact	16	Individual from whom the cash was received	23	Person on whose behalf transaction conducted	4	Business that received cash	3	Authorized official	8	Contact for assistance
Code	Description																				
35	Transmitter																				
37	Transmitter contact																				
16	Individual from whom the cash was received																				
23	Person on whose behalf transaction conducted																				
4	Business that received cash																				
3	Authorized official																				
8	Contact for assistance																				
Remarks:	The batch submission will be <u>rejected</u> if any of the following conditions are true: <ul style="list-style-type: none"> <li>• The element is not recorded.</li> </ul>																				

Element Name:	ActivityPartyTypeCode	minOccurs:	1	maxOccurs:	1
	<ul style="list-style-type: none"> <li>The element is recorded but with no value (i.e. the value is null).</li> <li>The element contains an invalid value.</li> </ul>				
Example:	<fc2:ActivityPartyTypeCode>16</fc2:ActivityPartyTypeCode>				

Element Name:	IndividualBirthDateText	minOccurs:	0	maxOccurs:	1
Description:	Date of birth (date). This element identifies the date of birth of the individual from whom the cash was received. This element corresponds with the following item(s): <ul style="list-style-type: none"> <li>8. Date of birth</li> </ul>				
Attribute(s)	n/a				
Parent Element:	Party				
Element Restriction(s):	Record this element when the party type is associated with the Individual from whom the cash was received (16) and the date of birth is known; otherwise, do not record this element.				
Value Restriction(s):	The value provided must conform to the following requirements: 8 numeric characters in the format YYYYMMDD where YYYY = year, MM = month, and DD = day. Single digit days or months must be prefaced by a zero. If the birth day and/or month is unknown, enter "00" for the unknown day or month. For example, a date of birth with an unknown day in February 1978 would be entered as 19780200. Do not enter zeros for the year if the year is unknown.				
Remarks:	<p>The batch submission will be <u>rejected</u> if any of the following conditions are true:</p> <ul style="list-style-type: none"> <li>The element is recorded for an inappropriate party type (see Element Restrictions for more information).</li> <li>The value is null or is not in the required format (YYYYMMDD).</li> </ul> <p>The batch submission will be <u>accepted with warning</u> if any of the following conditions are true:</p> <ul style="list-style-type: none"> <li>The date of birth recorded is greater than the date cash was received (TransactionDateText).</li> <li>The date of birth recorded is prior to January 1, 1900.</li> </ul>				
Example:	<fc2:IndividualBirthDateText>19801025</fc2:IndividualBirthDateText>				

Element Name:	PartyTypeCode	minOccurs:	0	maxOccurs:	1								
Description:	Party type (code). This element identifies the type of party associated with the Person on whose behalf transaction conducted, specifically, whether the party type is an entity, an individual, or unknown.												
Attribute(s)	n/a												
Parent Element:	Party												
Element Restriction(s):	This element must be recorded for the Person on whose behalf transaction conducted (23); otherwise, do not record this element.												
Value Restriction(s):	<p>The value provided must conform to the following requirements:</p> <table border="1"> <thead> <tr> <th>Code</th> <th>Description</th> </tr> </thead> <tbody> <tr> <td>O</td> <td>Organization/Entity</td> </tr> <tr> <td>I</td> <td>Individual</td> </tr> <tr> <td>U</td> <td>Unknown</td> </tr> </tbody> </table>					Code	Description	O	Organization/Entity	I	Individual	U	Unknown
Code	Description												
O	Organization/Entity												
I	Individual												
U	Unknown												
Remarks:	<p>The batch submission will be <u>rejected</u> if any of the following conditions are true:</p> <ul style="list-style-type: none"> <li>The element is not recorded for the Person on whose behalf transaction conducted (23) party type.</li> <li>The element is recorded for an inappropriate party type.</li> <li>The element is recorded but with no value (i.e. the value is null).</li> <li>The element contains an invalid value.</li> <li>The value is equal to "O" (Organization) and the Person on whose behalf transaction conducted organization name is not provided.</li> </ul>												
Example:	<fc2:PartyTypeCode>O</fc2:PartyTypeCode>												

Element Name:	PartyName	See <i>PartyName Elements</i> for details.
---------------	-----------	--

Element Name:	Address	See <i>Address Elements</i> for details.
---------------	---------	--

Element Name:	PhoneNumber	See <i>PhoneNumber Elements</i> for details.
---------------	-------------	--

Element Name:	PartyIdentification	See <i>PartyIdentification Elements</i> for details.
---------------	---------------------	--

Element Name:	PartyOccupationBusiness	See <i>PartyOccupationBusiness Elements</i> for details.
---------------	-------------------------	--

### 4.5.1. PartyName Elements

Element Name:	PartyName	minOccurs:	0	maxOccurs:	2																																																
Description:	<p>Party name (header). This is the container for information about the name of the party. The party name can be a legal name or Doing Business As (DBA) name depending on the party type identified. The following sub-elements are associated with this element:</p> <div style="background-color: #e1f5fe; padding: 10px; text-align: center;"> <p><b>Activity party type code definitions</b></p> <p>35 = Transmitter   37 = Transmitter Contact   3 = Authorized Official              8 = Contact for Assistance   16 = Individual from whom the cash was received              23 = Person on whose behalf transaction conducted   4 = Business that received cash</p> </div> <ol style="list-style-type: none"> <li>1. Transmitter: Legal name (Required   1 occurrence)                     <table border="1" style="width: 100%; margin-top: 5px;"> <thead> <tr> <th>Name</th> <th>minOccurs</th> <th>maxOccurs</th> <th>Content</th> </tr> </thead> <tbody> <tr> <td>PartyNameTypeCode (Code L)</td> <td>1</td> <td>1</td> <td>Simple</td> </tr> <tr> <td>RawPartyFullName</td> <td>1</td> <td>1</td> <td>Simple</td> </tr> </tbody> </table> </li> <li>2. Transmitter Contact: Legal name (Required   1 occurrence)                     <table border="1" style="width: 100%; margin-top: 5px;"> <thead> <tr> <th>Name</th> <th>minOccurs</th> <th>maxOccurs</th> <th>Content</th> </tr> </thead> <tbody> <tr> <td>PartyNameTypeCode (Code L)</td> <td>1</td> <td>1</td> <td>Simple</td> </tr> <tr> <td>RawPartyFullName</td> <td>1</td> <td>1</td> <td>Simple</td> </tr> </tbody> </table> </li> <li>3. Individual from whom the cash was received: Legal name (Required   Part I, Items 3-5   1 occurrence)                     <table border="1" style="width: 100%; margin-top: 5px;"> <thead> <tr> <th>Name</th> <th>minOccurs</th> <th>maxOccurs</th> <th>Content</th> </tr> </thead> <tbody> <tr> <td>RawEntityIndividualLastName (Item 3)</td> <td>1</td> <td>1</td> <td>Simple</td> </tr> <tr> <td>RawIndividualFirstName (Item 4)</td> <td>0</td> <td>1</td> <td>Simple</td> </tr> <tr> <td>RawIndividualMiddleName (Item 5)</td> <td>0</td> <td>1</td> <td>Simple</td> </tr> </tbody> </table> </li> <li>4. Person on whose behalf transaction conducted:                     <ol style="list-style-type: none"> <li>a. Legal name (If known   Part II, Items 16-18   0-1 occurrence)                             <table border="1" style="width: 100%; margin-top: 5px;"> <thead> <tr> <th>Name</th> <th>minOccurs</th> <th>maxOccurs</th> <th>Content</th> </tr> </thead> <tbody> <tr> <td>PartyNameTypeCode (Code L)</td> <td>1</td> <td>1</td> <td>Simple</td> </tr> </tbody> </table> </li> </ol> </li> </ol>					Name	minOccurs	maxOccurs	Content	PartyNameTypeCode (Code L)	1	1	Simple	RawPartyFullName	1	1	Simple	Name	minOccurs	maxOccurs	Content	PartyNameTypeCode (Code L)	1	1	Simple	RawPartyFullName	1	1	Simple	Name	minOccurs	maxOccurs	Content	RawEntityIndividualLastName (Item 3)	1	1	Simple	RawIndividualFirstName (Item 4)	0	1	Simple	RawIndividualMiddleName (Item 5)	0	1	Simple	Name	minOccurs	maxOccurs	Content	PartyNameTypeCode (Code L)	1	1	Simple
Name	minOccurs	maxOccurs	Content																																																		
PartyNameTypeCode (Code L)	1	1	Simple																																																		
RawPartyFullName	1	1	Simple																																																		
Name	minOccurs	maxOccurs	Content																																																		
PartyNameTypeCode (Code L)	1	1	Simple																																																		
RawPartyFullName	1	1	Simple																																																		
Name	minOccurs	maxOccurs	Content																																																		
RawEntityIndividualLastName (Item 3)	1	1	Simple																																																		
RawIndividualFirstName (Item 4)	0	1	Simple																																																		
RawIndividualMiddleName (Item 5)	0	1	Simple																																																		
Name	minOccurs	maxOccurs	Content																																																		
PartyNameTypeCode (Code L)	1	1	Simple																																																		

Element Name:	PartyName	minOccurs:	0	maxOccurs:	2																																				
	RawEntityIndividualLastName (Item 16)		0	1	Simple																																				
	RawIndividualFirstName (Item 17)		0	1	Simple																																				
	RawIndividualMiddleName (Item 18)		0	1	Simple																																				
	<p><i>Note: If the PartyName element is recorded for the Part II person legal name, then at least one entry must be recorded for Items 16-18; otherwise, do not record the PartyName element for the Part II person legal name.</i></p> <p>b. DBA name (If known   Part II, Item 20   0-1 occurrence)</p> <table border="1"> <thead> <tr> <th>Name</th> <th>minOccurs</th> <th>maxOccurs</th> <th>Content</th> </tr> </thead> <tbody> <tr> <td>PartyNameTypeCode (Code DBA)</td> <td>1</td> <td>1</td> <td>Simple</td> </tr> <tr> <td>RawPartyFullName (Item 20)</td> <td>1</td> <td>1</td> <td>Simple</td> </tr> </tbody> </table> <p>5. Business that received cash: Legal name (Required   Part IV, Item 35   1 occurrence)</p> <table border="1"> <thead> <tr> <th>Name</th> <th>minOccurs</th> <th>maxOccurs</th> <th>Content</th> </tr> </thead> <tbody> <tr> <td>RawPartyFullName (Item 35)</td> <td>1</td> <td>1</td> <td>Simple</td> </tr> </tbody> </table> <p>6. Authorized official: Title (If known   Part IV, Item 42   0-1 occurrence)</p> <table border="1"> <thead> <tr> <th>Name</th> <th>minOccurs</th> <th>maxOccurs</th> <th>Content</th> </tr> </thead> <tbody> <tr> <td>RawIndividualTitleText (Item 42)</td> <td>1</td> <td>1</td> <td>Simple</td> </tr> </tbody> </table> <p>7. Contact office: Name of person to contact (If known   Part IV, Items 44   0-1 occurrence)</p> <table border="1"> <thead> <tr> <th>Name</th> <th>minOccurs</th> <th>maxOccurs</th> <th>Content</th> </tr> </thead> <tbody> <tr> <td>RawPartyFullName (Item 44)</td> <td>1</td> <td>1</td> <td>Simple</td> </tr> </tbody> </table>					Name	minOccurs	maxOccurs	Content	PartyNameTypeCode (Code DBA)	1	1	Simple	RawPartyFullName (Item 20)	1	1	Simple	Name	minOccurs	maxOccurs	Content	RawPartyFullName (Item 35)	1	1	Simple	Name	minOccurs	maxOccurs	Content	RawIndividualTitleText (Item 42)	1	1	Simple	Name	minOccurs	maxOccurs	Content	RawPartyFullName (Item 44)	1	1	Simple
Name	minOccurs	maxOccurs	Content																																						
PartyNameTypeCode (Code DBA)	1	1	Simple																																						
RawPartyFullName (Item 20)	1	1	Simple																																						
Name	minOccurs	maxOccurs	Content																																						
RawPartyFullName (Item 35)	1	1	Simple																																						
Name	minOccurs	maxOccurs	Content																																						
RawIndividualTitleText (Item 42)	1	1	Simple																																						
Name	minOccurs	maxOccurs	Content																																						
RawPartyFullName (Item 44)	1	1	Simple																																						
Attribute(s)	<p>The following attributes must be recorded for this element:</p> <table border="1"> <thead> <tr> <th>Name</th> <th>Description</th> </tr> </thead> <tbody> <tr> <td>SeqNum</td> <td>The value recorded for this attribute must be numeric and unique. It may contain any numeric value up to 19 characters in length.</td> </tr> </tbody> </table>					Name	Description	SeqNum	The value recorded for this attribute must be numeric and unique. It may contain any numeric value up to 19 characters in length.																																
Name	Description																																								
SeqNum	The value recorded for this attribute must be numeric and unique. It may contain any numeric value up to 19 characters in length.																																								
Parent Element:	Party																																								
Element Restriction(s):	<p>Required. Record this element when reporting the name/title of a party. The following table describes the minimum and maximum reporting requirements per party type:</p> <table border="1"> <thead> <tr> <th>Party type</th> <th>Legal (min-max)</th> <th>DBA (min-max)</th> </tr> </thead> <tbody> <tr> <td>Transmitter</td> <td>1-1</td> <td>na</td> </tr> <tr> <td>Transmitter contact</td> <td>1-1</td> <td>na</td> </tr> <tr> <td>Individual from whom the cash was received</td> <td>1-1</td> <td>na</td> </tr> <tr> <td>Person on whose behalf transaction conducted</td> <td>0-1</td> <td>0-1</td> </tr> <tr> <td>Business that received cash</td> <td>1-1</td> <td>na</td> </tr> <tr> <td>Authorized official</td> <td>0-1</td> <td>na</td> </tr> <tr> <td>Contact office</td> <td>0-1</td> <td>na</td> </tr> </tbody> </table>					Party type	Legal (min-max)	DBA (min-max)	Transmitter	1-1	na	Transmitter contact	1-1	na	Individual from whom the cash was received	1-1	na	Person on whose behalf transaction conducted	0-1	0-1	Business that received cash	1-1	na	Authorized official	0-1	na	Contact office	0-1	na												
Party type	Legal (min-max)	DBA (min-max)																																							
Transmitter	1-1	na																																							
Transmitter contact	1-1	na																																							
Individual from whom the cash was received	1-1	na																																							
Person on whose behalf transaction conducted	0-1	0-1																																							
Business that received cash	1-1	na																																							
Authorized official	0-1	na																																							
Contact office	0-1	na																																							
Value Restriction(s):	n/a																																								
Remarks:	<p>The batch submission will be <u>rejected</u> if any of the following conditions are true:</p> <ul style="list-style-type: none"> <li>The element is recorded for a valid party type, but all sub-elements are missing.</li> </ul>																																								

Element Name:	PartyName	minOccurs:	0	maxOccurs:	2
	<ul style="list-style-type: none"> <li>The element is missing a "SeqNum" attribute.</li> <li>The element contains a "SeqNum" attribute with a duplicate or invalid value.</li> <li>More than one legal name is recorded for a single party type.</li> <li>More than one DBA name is recorded for the Person on whose behalf transaction conducted party type.</li> <li>A DBA name is recorded for a party type not equal to the Person on whose behalf transaction conducted.</li> </ul> <p>The batch submission will be <u>accepted with warning</u> if any of the following conditions are true:</p> <ul style="list-style-type: none"> <li>The legal name is not recorded for the Transmitter, Transmitter contact, Individual from whom the cash was received, and/or Business that received cash.</li> </ul>				
Example:	<pre>&lt;fc2:PartyName SeqNum="55"&gt;   &lt;fc2:PartyNameTypeCode&gt;L&lt;/fc2:PartyNameTypeCode&gt;   &lt;fc2:RawEntityIndividualLastName&gt;Bob's Business&lt;/fc2:RawEntityIndividualLastName&gt; &lt;/fc2:PartyName&gt; &lt;fc2:PartyName SeqNum="56"&gt;   &lt;fc2:PartyNameTypeCode&gt;DBA&lt;/fc2:PartyNameTypeCode&gt;   &lt;fc2:RawPartyFullName&gt;Bobby's Business&lt;/fc2:RawPartyFullName&gt; &lt;/fc2:PartyName&gt;</pre>				

Element Name:	PartyNameTypeCode	minOccurs:	1	maxOccurs:	1						
Description:	<p>Party name type (code). This element identifies the type of name recorded for the party; specifically, legal name or Doing Business As (DBA) name.</p> <p>This element corresponds with the following item(s):</p> <ul style="list-style-type: none"> <li>Transmitter <ul style="list-style-type: none"> <li>Name (legal)</li> </ul> </li> <li>Transmitter Contact <ul style="list-style-type: none"> <li>Name (legal)</li> </ul> </li> <li>Person on whose behalf transaction conducted <ul style="list-style-type: none"> <li>16-18. Last/Organization name, first name, middle initial (legal)</li> <li>20. Doing Business As name (DBA)</li> </ul> </li> </ul>										
Attribute(s)	n/a										
Parent Element:	PartyName										
Element Restriction(s):	Required. This element must be recorded.										
Value Restriction(s):	<p>The value provided must conform to the following requirements: Identify the party name type by recording the appropriate code from the list below:</p> <table border="1"> <thead> <tr> <th>Code</th> <th>Description</th> </tr> </thead> <tbody> <tr> <td>L</td> <td>Legal</td> </tr> <tr> <td>DBA</td> <td>Doing Business As*</td> </tr> </tbody> </table> <p>*DBA name type may only be used for the following party types:</p> <ul style="list-style-type: none"> <li>Person on whose behalf transaction conducted (23)</li> </ul>					Code	Description	L	Legal	DBA	Doing Business As*
Code	Description										
L	Legal										
DBA	Doing Business As*										
Remarks:	<p>The batch submission will be <u>rejected</u> if any of the following conditions are true:</p> <ul style="list-style-type: none"> <li>The element is not recorded and the associated party type is: Transmitter (35), Transmitter contact (37), or Person on whose behalf transaction conducted (23).</li> <li>The element is recorded for an inappropriate party type (see Element Restrictions for more information).</li> <li>The element is recorded but with no value (i.e. the value is null).</li> <li>The element contains an invalid value.</li> <li>The element is recorded with a value that is not approved for the associated party type (see Value Restrictions for more information).</li> </ul>										
Example:	<fc2:PartyNameTypeCode>L</fc2:PartyNameTypeCode>										

Element Name:	RawEntityIndividualLastName	minOccurs:	0	maxOccurs:	1
Description:	<p>Entity name or Individual last name (text). This element identifies the party's legal name, whether it be the legal name of the entity or the last name of the individual. This element corresponds with the following item(s):</p> <ul style="list-style-type: none"> <li>• Individual from whom the cash was received <ul style="list-style-type: none"> <li>○ 3. Last name</li> </ul> </li> <li>• Person on whose behalf transaction conducted <ul style="list-style-type: none"> <li>○ 16. Individual's last name or organization's name</li> </ul> </li> </ul> <p><i>Please refer to Attachment C General Instruction 16 "Name Editing Instructions" and line item instructions for additional information regarding these items.</i></p>				
Attribute(s)	n/a				
Parent Element:	PartyName				
Element Restriction(s):	<p>Record this element when the party type is associated with the:</p> <ul style="list-style-type: none"> <li>• Individual from whom the cash was received (16)</li> <li>• Person on whose behalf transaction conducted (23) and the last name/organization name of the person is known; otherwise, do not record this element.</li> </ul>				
Value Restriction(s):	The value provided must conform to the following requirements: 55 characters or less				
Remarks:	<p>The batch submission will be <u>rejected</u> if any of the following conditions are true:</p> <ul style="list-style-type: none"> <li>• The element is recorded for an inappropriate party type (see Element Restrictions for more information).</li> </ul>				
Example:	<fc2:RawEntityIndividualLastName>Williams</fc2:RawEntityIndividualLastName>				

Element Name:	RawIndividualFirstName	minOccurs:	0	maxOccurs:	1
Description:	<p>Individual first name (text). This element identifies the first name of the party. This element corresponds with the following item(s):</p> <ul style="list-style-type: none"> <li>• Individual from whom the cash was received <ul style="list-style-type: none"> <li>○ 4. First name</li> </ul> </li> <li>• Person on whose behalf transaction conducted <ul style="list-style-type: none"> <li>○ 17. First name</li> </ul> </li> </ul> <p><i>Please refer to Attachment C General Instruction 16 "Name Editing Instructions" and line item instructions for additional information regarding these items.</i></p>				
Attribute(s)	n/a				
Parent Element:	PartyName				
Element Restriction(s):	<p>Record this element when the party type is associated with the:</p> <ul style="list-style-type: none"> <li>• Individual from whom the cash was received (16) and the first name is known.</li> <li>• Person on whose behalf transaction conducted (23) and the first name is known.</li> </ul> <p>Otherwise, do not record this element.</p>				
Value Restriction(s):	The value provided must conform to the following requirements: 20 characters or less				
Remarks:	<p>The batch submission will be <u>rejected</u> if any of the following conditions are true:</p> <ul style="list-style-type: none"> <li>• The element is recorded for an inappropriate party type (see Element Restrictions for more information).</li> </ul>				
Example:	<fc2:RawIndividualFirstName>Jessica</fc2:RawIndividualFirstName>				

Element Name:	RawIndividualMiddleName	minOccurs:	0	maxOccurs:	1
Description:	<p>Individual middle initial (text). This element identifies the middle initial of the party. This element corresponds with the following item(s):</p> <ul style="list-style-type: none"> <li>• Individual from whom the cash was received</li> </ul>				



Element Name:	RawIndividualMiddleName	minOccurs:	0	maxOccurs:	1
	<ul style="list-style-type: none"> <li>○ 5. Middle Initial</li> <li>● Person on whose behalf transaction conducted                             <ul style="list-style-type: none"> <li>○ 18. Middle Initial</li> </ul> </li> </ul> <p><i>Please refer to Attachment C General Instruction 16 "Name Editing Instructions" and line item instructions for additional information regarding these items.</i></p>				
Attribute(s)	n/a				
Parent Element:	PartyName				
Element Restriction(s):	Record this element when the party type is associated with the: <ul style="list-style-type: none"> <li>● Individual from whom the cash was received (16) and the middle initial is known.</li> <li>● Person on whose behalf transaction conducted (23) and the middle initial is known.</li> </ul> Otherwise, do not record this element.				
Value Restriction(s):	The value provided must conform to the following requirements: 1 character				
Remarks:	The batch submission will be <u>rejected</u> if any of the following conditions are true: <ul style="list-style-type: none"> <li>● The element is recorded for an inappropriate party type (see Element Restrictions for more information).</li> </ul>				
Example:	<fc2:RawIndividualMiddleName> R</fc2:RawIndividualMiddleName>				

Element Name:	RawIndividualTitleText	minOccurs:	0	maxOccurs:	1
Description:	Title (text). This element identifies the title of the official authorized to review and approve the contents of the FinCEN Form 8300. This element corresponds with the following item: <ul style="list-style-type: none"> <li>● 42. Title</li> </ul>				
Attribute(s)	n/a				
Parent Element:	PartyName				
Element Restriction(s):	Record this element when the party type is associated with the authorized official (3) and the title of the authorized official is known; otherwise, do not record this element.				
Value Restriction(s):	The value provided must conform to the following requirements: 35 characters or less				
Remarks:	The batch submission will be <u>rejected</u> if any of the following conditions are true: <ul style="list-style-type: none"> <li>● The element is recorded for an inappropriate party type (see Element Restrictions for more information).</li> </ul>				
Example:	<pre>&lt;fc2:Party SeqNum="96"&gt;   &lt;fc2:ActivityPartyTypeCode&gt;3&lt;/fc2:ActivityPartyTypeCode&gt;   &lt;fc2:PartyName SeqNum="97"&gt;     &lt;fc2:RawIndividualTitleText&gt;Authorizing person title&lt;/fc2:RawIndividualTitleText&gt;   &lt;/fc2:PartyName&gt; &lt;/fc2:Party&gt;</pre>				

Element Name:	RawPartyFullName	minOccurs:	0	maxOccurs:	1
Description:	Party full name (text). This element identifies the full name of the party, whether it be the legal name or a DBA name of an institution or individual. This element corresponds with the following item(s): <ul style="list-style-type: none"> <li>● Transmitter                             <ul style="list-style-type: none"> <li>○ Name (legal)</li> </ul> </li> <li>● Transmitter Contact                             <ul style="list-style-type: none"> <li>○ Name (legal)</li> </ul> </li> <li>● Person on whose behalf transaction conducted                             <ul style="list-style-type: none"> <li>○ 20. Doing Business As (DBA) name</li> </ul> </li> <li>● Business that received cash                             <ul style="list-style-type: none"> <li>○ 35. Name of business that received cash</li> <li>○ 44. Name of person to contact</li> </ul> </li> </ul>				

Element Name:	RawPartyFullName	minOccurs:	0	maxOccurs:	1
	<i>Please refer to Attachment C General Instruction 16 "Name Editing Instructions" and line item instructions for additional information regarding these items.</i>				
Attribute(s)	n/a				
Parent Element:	PartyName				
Element Restriction(s):	Record this element for the following party types and conditions; otherwise, do not record this element: <ul style="list-style-type: none"> <li>• The name is associated with the following party types:                         <ul style="list-style-type: none"> <li>○ Transmitter (35) legal name</li> <li>○ Transmitter Contact (37) legal name (NOTE: The value recorded must be the name of the individual to be contacted on issues involving the batch file. This entry must be the same for all FinCEN Form 8300 in the batch file.)</li> <li>○ Person on whose behalf transaction conducted (23) DBA name and the DBA name is known; otherwise, this element (along with the PartyName element) should not be recorded for the DBA name.</li> <li>○ Business that received cash (4) legal name</li> <li>○ Contact Office (8) title of the administrative office. (NOTE: The value recorded must be the title of the administrative office (such as Compliance Office) that should be contacted for additional information about the FinCEN Form 8300.)</li> </ul> </li> </ul>				
Value Restriction(s):	The value provided must conform to the following requirements: 55 characters or less				
Remarks:	The batch submission will be <u>rejected</u> if any of the following conditions are true: <ul style="list-style-type: none"> <li>• The element is recorded for an inappropriate party type (see Element Restrictions for more information).</li> </ul> The batch submission will be <u>accepted with warning</u> if any of the following conditions are true: <ul style="list-style-type: none"> <li>• The element is not recorded or does not contain a value for the Business that received cash.</li> </ul>				
Example:	<pre>&lt;fc2:Party SeqNum="105"&gt;   &lt;fc2:ActivityPartyTypeCode&gt;4&lt;/fc2:ActivityPartyTypeCode&gt;   &lt;fc2:PartyName SeqNum="106"&gt;     &lt;fc2:RawPartyFullName&gt;Frank's Auto Park&lt;/fc2:RawPartyFullName&gt;   &lt;/fc2:PartyName&gt;</pre>				

### 4.5.2. Address Elements

Element Name:	Address	minOccurs:	0	maxOccurs:	1																								
Description:	Address (header). This is the container for information about the address of the party.  <i>Please refer to General Instruction "11. Addresses" and line item address instructions in Attachment C – Electronic XML Filing Instructions for additional information on completing this element.</i>  The following sub-element is associated with this element: <div style="background-color: #e1f5fe; padding: 10px; margin: 10px 0;"> <p style="text-align: center;"><b>Activity party type code definitions</b></p> <p style="text-align: center;">35 = Transmitter   16 = Individual from whom the cash was received 23 = Person on whose behalf transaction conducted   4 = Business that received cash</p> </div> <ol style="list-style-type: none"> <li>1. Transmitter Information: Address (Required)</li> </ol> <table border="1" style="width: 100%; border-collapse: collapse;"> <thead> <tr> <th style="background-color: #e1f5fe;">Name</th> <th>minOccurs</th> <th>maxOccurs</th> <th>Content</th> </tr> </thead> <tbody> <tr> <td>RawCityText</td> <td style="text-align: center;">1</td> <td style="text-align: center;">1</td> <td>Simple</td> </tr> <tr> <td>RawCountryCodeText</td> <td style="text-align: center;">1</td> <td style="text-align: center;">1</td> <td>Simple</td> </tr> <tr> <td>RawStateCodeText</td> <td style="text-align: center;">1</td> <td style="text-align: center;">1</td> <td>Simple</td> </tr> <tr> <td>RawStreetAddress1Text</td> <td style="text-align: center;">1</td> <td style="text-align: center;">1</td> <td>Simple</td> </tr> <tr> <td>RawZIPCode</td> <td style="text-align: center;">1</td> <td style="text-align: center;">1</td> <td>Simple</td> </tr> </tbody> </table>					Name	minOccurs	maxOccurs	Content	RawCityText	1	1	Simple	RawCountryCodeText	1	1	Simple	RawStateCodeText	1	1	Simple	RawStreetAddress1Text	1	1	Simple	RawZIPCode	1	1	Simple
Name	minOccurs	maxOccurs	Content																										
RawCityText	1	1	Simple																										
RawCountryCodeText	1	1	Simple																										
RawStateCodeText	1	1	Simple																										
RawStreetAddress1Text	1	1	Simple																										
RawZIPCode	1	1	Simple																										

Element Name:	Address	minOccurs:	0	maxOccurs:	1																																																																				
	<p>2. Individual from whom the cash was received: Address (If known   Part I, Items 7, 9-12)</p> <table border="1"> <thead> <tr> <th>Name</th> <th>minOccurs</th> <th>maxOccurs</th> <th>Content</th> </tr> </thead> <tbody> <tr> <td>RawCityText (Item 9)</td> <td>0</td> <td>1</td> <td>Simple</td> </tr> <tr> <td>RawCountryCodeText (Item 12)</td> <td>0</td> <td>1</td> <td>Simple</td> </tr> <tr> <td>RawStateCodeText (Item 10)</td> <td>0</td> <td>1</td> <td>Simple</td> </tr> <tr> <td>RawStreetAddress1Text (Item 7)</td> <td>0</td> <td>1</td> <td>Simple</td> </tr> <tr> <td>RawZIPCode (Item 11)</td> <td>0</td> <td>1</td> <td>Simple</td> </tr> </tbody> </table> <p><i>NOTE: If the Address element is recorded for this party type, then at least one address sub-element from the above list must be recorded with a value; otherwise, do not record the Address element for this party.</i></p> <p>3. Person on whose behalf transaction conducted: Address (If known   Part II, Items 21, 23-26)</p> <table border="1"> <thead> <tr> <th>Name</th> <th>minOccurs</th> <th>maxOccurs</th> <th>Content</th> </tr> </thead> <tbody> <tr> <td>RawCityText (Item 23)</td> <td>0</td> <td>1</td> <td>Simple</td> </tr> <tr> <td>RawCountryCodeText (Item 26)</td> <td>0</td> <td>1</td> <td>Simple</td> </tr> <tr> <td>RawStateCodeText (Item 24)</td> <td>0</td> <td>1</td> <td>Simple</td> </tr> <tr> <td>RawStreetAddress1Text (Item 21)</td> <td>0</td> <td>1</td> <td>Simple</td> </tr> <tr> <td>RawZIPCode (Item 25)</td> <td>0</td> <td>1</td> <td>Simple</td> </tr> </tbody> </table> <p><i>NOTE: If the Address element is recorded for this party type, then at least one address sub-element from the above list must be recorded with a value; otherwise, do not record the Address element for this party.</i></p> <p>4. Business that received cash: Address (If known   Part IV, Items 37-40)</p> <table border="1"> <thead> <tr> <th>Name</th> <th>minOccurs</th> <th>maxOccurs</th> <th>Content</th> </tr> </thead> <tbody> <tr> <td>RawCityText (Item 38)</td> <td>0</td> <td>1</td> <td>Simple</td> </tr> <tr> <td>RawStateCodeText (Item 39)</td> <td>0</td> <td>1</td> <td>Simple</td> </tr> <tr> <td>RawStreetAddress1Text (Item 37)</td> <td>0</td> <td>1</td> <td>Simple</td> </tr> <tr> <td>RawZIPCode (Item 40)</td> <td>0</td> <td>1</td> <td>Simple</td> </tr> </tbody> </table> <p><i>NOTE: If the Address element is recorded for this party type, then at least one address sub-element from the above list must be recorded with a value; otherwise, do not record the Address element for this party.</i></p>					Name	minOccurs	maxOccurs	Content	RawCityText (Item 9)	0	1	Simple	RawCountryCodeText (Item 12)	0	1	Simple	RawStateCodeText (Item 10)	0	1	Simple	RawStreetAddress1Text (Item 7)	0	1	Simple	RawZIPCode (Item 11)	0	1	Simple	Name	minOccurs	maxOccurs	Content	RawCityText (Item 23)	0	1	Simple	RawCountryCodeText (Item 26)	0	1	Simple	RawStateCodeText (Item 24)	0	1	Simple	RawStreetAddress1Text (Item 21)	0	1	Simple	RawZIPCode (Item 25)	0	1	Simple	Name	minOccurs	maxOccurs	Content	RawCityText (Item 38)	0	1	Simple	RawStateCodeText (Item 39)	0	1	Simple	RawStreetAddress1Text (Item 37)	0	1	Simple	RawZIPCode (Item 40)	0	1	Simple
Name	minOccurs	maxOccurs	Content																																																																						
RawCityText (Item 9)	0	1	Simple																																																																						
RawCountryCodeText (Item 12)	0	1	Simple																																																																						
RawStateCodeText (Item 10)	0	1	Simple																																																																						
RawStreetAddress1Text (Item 7)	0	1	Simple																																																																						
RawZIPCode (Item 11)	0	1	Simple																																																																						
Name	minOccurs	maxOccurs	Content																																																																						
RawCityText (Item 23)	0	1	Simple																																																																						
RawCountryCodeText (Item 26)	0	1	Simple																																																																						
RawStateCodeText (Item 24)	0	1	Simple																																																																						
RawStreetAddress1Text (Item 21)	0	1	Simple																																																																						
RawZIPCode (Item 25)	0	1	Simple																																																																						
Name	minOccurs	maxOccurs	Content																																																																						
RawCityText (Item 38)	0	1	Simple																																																																						
RawStateCodeText (Item 39)	0	1	Simple																																																																						
RawStreetAddress1Text (Item 37)	0	1	Simple																																																																						
RawZIPCode (Item 40)	0	1	Simple																																																																						
Attribute(s)	<p>The following attributes must be recorded for this element:</p> <table border="1"> <thead> <tr> <th>Name</th> <th>Description</th> </tr> </thead> <tbody> <tr> <td>SeqNum</td> <td>The value recorded for this attribute must be numeric and unique. It may contain any numeric value up to 19 characters in length.</td> </tr> </tbody> </table>					Name	Description	SeqNum	The value recorded for this attribute must be numeric and unique. It may contain any numeric value up to 19 characters in length.																																																																
Name	Description																																																																								
SeqNum	The value recorded for this attribute must be numeric and unique. It may contain any numeric value up to 19 characters in length.																																																																								
Parent Element:	Party																																																																								
Element Restriction(s):	<p>Required. This element must be recorded for the following party types (activity level):</p> <table border="1"> <thead> <tr> <th>Party type</th> <th>Address (min-max)</th> </tr> </thead> <tbody> <tr> <td>Transmitter</td> <td>1-1</td> </tr> <tr> <td>Individual from whom the cash was received</td> <td>0-1</td> </tr> <tr> <td>Person on whose behalf transaction conducted</td> <td>0-1</td> </tr> <tr> <td>Business that received cash</td> <td>0-1</td> </tr> </tbody> </table>					Party type	Address (min-max)	Transmitter	1-1	Individual from whom the cash was received	0-1	Person on whose behalf transaction conducted	0-1	Business that received cash	0-1																																																										
Party type	Address (min-max)																																																																								
Transmitter	1-1																																																																								
Individual from whom the cash was received	0-1																																																																								
Person on whose behalf transaction conducted	0-1																																																																								
Business that received cash	0-1																																																																								
Value Restriction(s):	n/a																																																																								

Element Name:	Address	minOccurs:	0	maxOccurs:	1
Remarks:	<p>The batch submission will be <u>rejected</u> if any of the following conditions are true:</p> <ul style="list-style-type: none"> <li>The element is recorded for an inappropriate party type (see Element Restrictions for more information).</li> <li>The element is recorded for a valid party type, but all sub-elements are missing.</li> <li>The element is missing a "SeqNum" attribute.</li> <li>The element contains a "SeqNum" attribute with a duplicate or invalid value.</li> </ul> <p>The batch submission will be <u>accepted with warning</u> if any of the following conditions are true:</p> <ul style="list-style-type: none"> <li>The element is not recorded for Transmitter.</li> </ul>				
Example:	<pre>&lt;fc2:Address SeqNum="25"&gt;   &lt;fc2:RawCityText&gt;Silver Spring&lt;/fc2:RawCityText&gt;   &lt;fc2:RawCountryCodeText&gt;US&lt;/fc2:RawCountryCodeText&gt;   &lt;fc2:RawStateCodeText&gt;MD&lt;/fc2:RawStateCodeText&gt;   &lt;fc2:RawStreetAddress1Text&gt;789 Street&lt;/fc2:RawStreetAddress1Text&gt;   &lt;fc2:RawZIPCode&gt;54789&lt;/fc2:RawZIPCode&gt; &lt;/fc2:Address&gt;</pre>				

Element Name:	RawCityText	minOccurs:	0	maxOccurs:	1
Description:	<p>City (text). This element identifies the city associated with the address of the party. This element corresponds with the following item(s):</p> <ul style="list-style-type: none"> <li>Transmitter: City</li> <li>Individual from whom the cash was received: 9. City</li> <li>Person on whose behalf transaction conducted: 23. City</li> <li>Business that received cash: 38. City</li> </ul> <p><i>Please refer to General Instruction "11. Addresses" and line item address instructions in Attachment C – Electronic XML Filing Instructions for additional information on completing this element.</i></p>				
Attribute(s)	n/a				
Parent Element:	Address				
Element Restriction(s):	<p>Required. This element must be recorded for the following party types:</p> <ul style="list-style-type: none"> <li>Transmitter (35)</li> </ul> <p>Record this element when the city is known for the following party types; otherwise, do not record the element:</p> <ul style="list-style-type: none"> <li>Individual from whom the cash was received (16)</li> <li>Person on whose behalf transaction conducted (23)</li> <li>Business that received cash (4)</li> </ul>				
Value Restriction(s):	The value provided must conform to the following requirements: 25 characters or less.				
Remarks:	<p>The batch submission will be <u>accepted with warning</u> if any of the following conditions are true:</p> <ul style="list-style-type: none"> <li>The element is not recorded or does not contain a value for the Transmitter.</li> </ul>				
Example:	<fc2:RawCityText>Orlando</fc2:RawCityText>				

Element Name:	RawCountryCodeText	minOccurs:	0	maxOccurs:	1
Description:	<p>Country (code). This element identifies the country associated with the party. This element corresponds with the following item(s):</p> <ul style="list-style-type: none"> <li>Transmitter: Country code</li> <li>Individual from whom the cash was received: 12. Country code</li> <li>Person on whose behalf transaction conducted: 26. Country code</li> </ul> <p><i>NOTE: The Business that received cash (4) party type does NOT include a country entry, as the country by default should be a U.S. (or U.S. Territory).</i></p>				

Element Name:	RawCountryCodeText	minOccurs:	0	maxOccurs:	1
	<i>Please refer to General Instruction "11. Addresses" and line item address instructions in Attachment C – Electronic XML Filing Instructions for additional information on completing this element.</i>				
Attribute(s)	n/a				
Parent Element:	Address				
Element Restriction(s):	<p>Required. This element must be recorded for the following party types:</p> <ul style="list-style-type: none"> <li>• Transmitter (35)</li> </ul> <p>Record this element when the country is known* for the following party types; otherwise, do not record the element:</p> <ul style="list-style-type: none"> <li>• Individual from whom the cash was received (16)</li> <li>• Person on whose behalf transaction conducted (23)</li> </ul>				
Value Restriction(s):	The value provided must conform to the following requirements: Country codes (including U.S. Territory codes) must adhere to the two-letter country codes found in ISO 3166-2.				
Remarks:	<p>The batch submission will be <u>rejected</u> if any of the following conditions are true:</p> <ul style="list-style-type: none"> <li>• The element is recorded for the Business that received cash party type.</li> </ul> <p>The batch submission will be <u>accepted with warning</u> if any of the following conditions are true:</p> <ul style="list-style-type: none"> <li>• The value recorded is not a valid country code.</li> <li>• The element is not recorded or does not contain a value for the Transmitter.</li> <li>• State code and country code mismatch when U.S. Territory is recorded (NOTE: This validation is not applicable for Business that received cash party type).</li> </ul>				
Example:	<fc2:RawCountryCodeText>US</fc2:RawCountryCodeText>				

Element Name:	RawStateCodeText	minOccurs:	0	maxOccurs:	1
Description:	<p>State/Territory/Province (code). This element identifies the state/territory/province associated with the address of the party when the corresponding country is equal to US (United States), CA (Canada), MX (Mexico), or a U.S. Territory. This element corresponds with the following item(s):</p> <ul style="list-style-type: none"> <li>• Transmitter: State code</li> <li>• Individual from whom the cash was received: 10. State code</li> <li>• Person on whose behalf transaction conducted: 24. State code</li> <li>• Business that received cash: 39. State code</li> </ul> <p><i>Please refer to General Instruction "11. Addresses" and line item address instructions in Attachment C – Electronic XML Filing Instructions for additional information on completing this element.</i></p>				
Attribute(s)	n/a				
Parent Element:	Address				
Element Restriction(s):	<p>Record this element for the following party type when the corresponding country is US (United States), a U.S. Territory, CA (Canada), or MX (Mexico); otherwise, do not record this element. <i>NOTE: If the corresponding country is a U.S. Territory, then the state element should be recorded with the same U.S. Territory code.</i></p> <ul style="list-style-type: none"> <li>• Transmitter (35)</li> </ul> <p>Record this element for the following party types when the corresponding country is US (United States), a U.S. Territory, CA (Canada), or MX (Mexico) and the state is known; otherwise, do not record this element. <i>NOTE: If the corresponding country is a U.S. Territory, then the state element should be recorded with the same U.S. Territory code.</i></p> <ul style="list-style-type: none"> <li>• Individual from whom the cash was received (16)</li> <li>• Person on whose behalf transaction conducted (23)</li> </ul> <p>Record this element for the following party type when U.S. state/territory is known; otherwise, do not record this element.</p> <ul style="list-style-type: none"> <li>• Business that received cash (4)</li> </ul>				
Value Restriction(s):	<p>The value provided must conform to the following requirements:</p> <ul style="list-style-type: none"> <li>• 2-3 character alpha code.</li> <li>• United States state/territory codes must adhere to the two-letter codes used by the United States Postal Service when the country is equal to US or a U.S. Territory.</li> <li>• If a U.S. Territory is recorded for the country, it must also be recorded for the state.</li> </ul>				

Element Name:	RawStateCodeText	minOccurs:	0	maxOccurs:	1
	<ul style="list-style-type: none"> <li>Canadian province and territory codes must conform to ISO 3166-2:CA.</li> <li>Mexican state/federal district codes must adhere to the standards of ISO 3166-2:MX when the country is equal to MX.</li> </ul>				
Remarks:	<p>The batch submission will be <u>accepted with warning</u> if any of the following conditions are true:</p> <ul style="list-style-type: none"> <li>The value recorded is not a valid state code.</li> <li>The element is not recorded or does not contain a value for the transmitter when the country is US, CA, MX, or a U.S. Territory.</li> <li>The element contains a value and the country is not US, CA, MX, or a U.S. Territory.</li> <li>State code and country code mismatch when U.S. Territory is recorded.</li> </ul>				
Example:	<fc2:RawStateCodeText>VA</fc2:RawStateCodeText>				

Element Name:	RawStreetAddress1Text	minOccurs:	0	maxOccurs:	1
Description:	<p>Street address (text). This element identifies the street address of the party. This element corresponds with the following item(s):</p> <ul style="list-style-type: none"> <li>Transmitter: Street Address</li> <li>Individual from whom the cash was received: 7. Street Address</li> <li>Person on whose behalf transaction conducted: 21. Street Address</li> <li>Business that received cash: 37. Street Address</li> </ul> <p><i>Please refer to General Instruction "11. Addresses" and line item address instructions in Attachment C – Electronic XML Filing Instructions for additional information on completing this element.</i></p>				
Attribute(s)	n/a				
Parent Element:	Address				
Element Restriction(s):	<p>Required. This element must be recorded for the following party types:</p> <ul style="list-style-type: none"> <li>Transmitter (35)</li> </ul> <p>Record this element when the street address is known for the following party types; otherwise, do not record this element:</p> <ul style="list-style-type: none"> <li>Individual from whom the cash was received (16)</li> <li>Person on whose behalf transaction conducted (23)</li> <li>Business that received cash (4)</li> </ul>				
Value Restriction(s):	The value provided must conform to the following requirements: 50 characters or less				
Remarks:	<p>The batch submission will be <u>accepted with warning</u> if any of the following conditions are true:</p> <ul style="list-style-type: none"> <li>The element is not recorded or does not contain a value for the Transmitter.</li> </ul>				
Example:	<fc2:RawStreetAddress1Text>987 Rocky Road</fc2:RawStreetAddress1Text>				

Element Name:	RawZIPCode	minOccurs:	0	maxOccurs:	1
Description:	<p>ZIP/Postal Code (text). This element identifies the ZIP Code (or foreign postal code) associated with the address of the party. This element corresponds with the following item(s):</p> <ul style="list-style-type: none"> <li>Transmitter: ZIP/Foreign Postal Code</li> <li>Individual from whom the cash was received: 11. ZIP/Foreign Postal Code</li> <li>Person on whose behalf transaction conducted: 25. ZIP/Foreign Postal Code</li> <li>Business that received cash: 40. ZIP Code</li> </ul> <p><i>Please refer to General Instruction "11. Addresses" and line item address instructions in Attachment C – Electronic XML Filing Instructions for additional information on completing this element.</i></p>				
Attribute(s)	n/a				
Parent Element:	Address				
Element Restriction(s):	<p>Required. This element must be recorded for the following party types:</p> <ul style="list-style-type: none"> <li>Transmitter (35)</li> </ul>				

Element Name:	RawZIPCode	minOccurs:	0	maxOccurs:	1
	Record this element when the ZIP Code (or foreign postal code) is known for the following party types; otherwise, do not record this element: <ul style="list-style-type: none"> <li>Individual from whom the cash was received (16)</li> <li>Person on whose behalf transaction conducted (23)</li> <li>Business that received cash (4)*</li> </ul> *NOTE: The Business that received cash (4) should always be a U.S. (or U.S. Territory) location; therefore, this element should only contain U.S. (or U.S. Territory) ZIP Codes (if known).				
Value Restriction(s):	The value provided must conform to the following requirements: For a U.S. address (including U.S. Territories): 5 or 9 numeric character entry; 9 numeric character entry cannot end with four zeros or four nines. For a non-U.S. address: 9 (or less) alphanumeric character entry. Do not include punctuation or formatting such as hyphens, periods, and spaces within the value entry				
Remarks:	The batch submission will be <u>accepted with warning</u> if any of the following conditions are true: <ul style="list-style-type: none"> <li>The element is not recorded or does not contain a value for Transmitter</li> <li>The value recorded is not equal to 5 or 9 numeric characters, is a 9-digit value ending in four zeros or four nines, and the corresponding country is equal to US or a U.S. Territory code.</li> </ul>				
Example:	<fc2:RawZIPCode>87598</fc2:RawZIPCode>				

### 4.5.3. PhoneNumber Elements

Element Name:	PhoneNumber	minOccurs:	0	maxOccurs:	1																
Description:	Telephone number (header). This is the container for information about the telephone number of the party.  The following sub-element is associated with this element: <div style="background-color: #e1f5fe; padding: 10px; text-align: center; margin: 10px 0;"> <b>Activity party type code definitions</b>                      35 = Transmitter   8 = Contact for Assistance                 </div> <ol style="list-style-type: none"> <li>Transmitter: Telephone (Required)                     <table border="1" style="width: 100%; margin-top: 5px;"> <thead> <tr> <th>Name</th> <th>minOccurs</th> <th>maxOccurs</th> <th>Content</th> </tr> </thead> <tbody> <tr> <td>PhoneNumberText</td> <td>1</td> <td>1</td> <td>Simple</td> </tr> </tbody> </table> </li> <li>Contact for assistance: Telephone (If known   Part IV, Item 45)                     <table border="1" style="width: 100%; margin-top: 5px;"> <thead> <tr> <th>Name</th> <th>minOccurs</th> <th>maxOccurs</th> <th>Content</th> </tr> </thead> <tbody> <tr> <td>PhoneNumberText (Item 45)</td> <td>1</td> <td>1</td> <td>Simple</td> </tr> </tbody> </table> </li> </ol>					Name	minOccurs	maxOccurs	Content	PhoneNumberText	1	1	Simple	Name	minOccurs	maxOccurs	Content	PhoneNumberText (Item 45)	1	1	Simple
Name	minOccurs	maxOccurs	Content																		
PhoneNumberText	1	1	Simple																		
Name	minOccurs	maxOccurs	Content																		
PhoneNumberText (Item 45)	1	1	Simple																		
Attribute(s)	The following attributes must be recorded for this element: <table border="1" style="width: 100%; margin-top: 5px;"> <thead> <tr> <th>Name</th> <th>Description</th> </tr> </thead> <tbody> <tr> <td>SeqNum</td> <td>The value recorded for this attribute must be numeric and unique. It may contain any numeric value up to 19 characters in length.</td> </tr> </tbody> </table>					Name	Description	SeqNum	The value recorded for this attribute must be numeric and unique. It may contain any numeric value up to 19 characters in length.												
Name	Description																				
SeqNum	The value recorded for this attribute must be numeric and unique. It may contain any numeric value up to 19 characters in length.																				
Parent Element:	Party																				
Element Restriction(s):	Required. This element must be recorded for the following party types (activity level): <table border="1" style="width: 100%; margin-top: 5px;"> <thead> <tr> <th>Party type</th> <th>Telephone (min-max)</th> </tr> </thead> <tbody> <tr> <td>Transmitter</td> <td>1-1</td> </tr> <tr> <td>Contact for assistance</td> <td>0-1</td> </tr> </tbody> </table>					Party type	Telephone (min-max)	Transmitter	1-1	Contact for assistance	0-1										
Party type	Telephone (min-max)																				
Transmitter	1-1																				
Contact for assistance	0-1																				

Element Name:	PhoneNumber	minOccurs:	0	maxOccurs:	1
Value Restriction(s):	n/a				
Remarks:	<p>The batch submission will be <u>rejected</u> if any of the following conditions are true:</p> <ul style="list-style-type: none"> <li>The element is recorded for an inappropriate party type (see Element Restrictions for more information).</li> <li>The element is recorded for a valid party type, but all sub-elements are missing.</li> <li>The element is missing a "SeqNum" attribute.</li> <li>The element contains a "SeqNum" attribute with a duplicate or invalid value.</li> </ul>				
Example:	<pre>&lt;fc2:PhoneNumber SeqNum="98"&gt;   &lt;fc2:PhoneNumberText&gt;4589774512&lt;/fc2:PhoneNumberText&gt; &lt;/fc2:PhoneNumber&gt;</pre>				

Element Name:	PhoneNumberText	minOccurs:	1	maxOccurs:	1
Description:	<p>Telephone number (text). This element identifies the telephone number of the party. This element corresponds with the following item(s):</p> <ul style="list-style-type: none"> <li>Transmitter: Phone number</li> <li>Contact for assistance: 45. Contact telephone number</li> </ul> <p><i>Please refer to General Instruction "15. Telephone numbers" and line item phone number instructions in Attachment C – Electronic XML Filing Instructions for additional information on completing this element.</i></p>				
Attribute(s)	n/a				
Parent Element:	PhoneNumber				
Element Restriction(s):	<p>Record this element for the following party types and circumstances; otherwise, do not record this element:</p> <ul style="list-style-type: none"> <li>Transmitter (35)</li> <li>Contact for assistance (8) and the telephone number is known</li> </ul>				
Value Restriction(s):	<p>The value provided must conform to the following requirements:</p> <ul style="list-style-type: none"> <li>Transmitter (35): 1-16 numeric characters; not all same digit (such as all 0's or all 9's).</li> <li>Contact for assistance (8): 10 numeric characters; not all same digit (such as all 0's or all 9's).</li> </ul> <p>Do not include punctuation or formatting such as hyphens, periods, and spaces within the value entry regardless of party type. <i>NOTE: For the Transmitter (35) party type, this number must be the same for all FinCEN Form 8300's in the batch file.</i></p>				
Remarks:	<p>The batch submission will be <u>rejected</u> if any of the following conditions are true:</p> <ul style="list-style-type: none"> <li>The element is not recorded and the parent element is recorded.</li> </ul> <p>The batch submission will be <u>accepted with warning</u> if any of the following conditions are true:</p> <ul style="list-style-type: none"> <li>The element is recorded but does not contain a value for the Transmitter.</li> <li>The element is recorded but does not contain a value for the Contact for assistance.</li> <li>The value recorded does not equal 10 numeric characters.</li> </ul>				
Example:	<pre>&lt;fc2:PhoneNumberText&gt;6194760276&lt;/fc2:PhoneNumberText&gt;</pre>				

#### 4.5.4. PartyIdentification Elements

Element Name:	PartyIdentification	minOccurs:	0	maxOccurs:	3
Description:	<p>Party identification (header). This is the container for information about the identification associated with the party.</p> <p>The following sub-element is associated with this element:</p> <div style="background-color: #e1f5fe; padding: 10px; margin: 10px 0;"> <p style="text-align: center;"><b>Activity party type code definitions</b></p> <p style="text-align: center;">35 = Transmitter   16 = Individual from whom the cash was received  23 = Person on whose behalf transaction conducted   4 = Business that received cash</p> </div>				



Element Name:	PartyIdentification	minOccurs:	0	maxOccurs:	3																																																																																				
<p>1. Transmitter Information</p> <p>a. Transmitter Control Code (TCC) (Required)</p> <table border="1"> <thead> <tr> <th>Name</th> <th>minOccurs</th> <th>maxOccurs</th> <th>Content</th> </tr> </thead> <tbody> <tr> <td>PartyIdentificationNumberText</td> <td>1</td> <td>1</td> <td>Simple</td> </tr> <tr> <td>PartyIdentificationTypeCode (Code 28)</td> <td>1</td> <td>1</td> <td>Simple</td> </tr> </tbody> </table> <p>b. Taxpayer Identification Number (EIN) (Required)</p> <table border="1"> <thead> <tr> <th>Name</th> <th>minOccurs</th> <th>maxOccurs</th> <th>Content</th> </tr> </thead> <tbody> <tr> <td>PartyIdentificationNumberText</td> <td>1</td> <td>1</td> <td>Simple</td> </tr> <tr> <td>PartyIdentificationTypeCode (Code 2)</td> <td>1</td> <td>1</td> <td>Simple</td> </tr> </tbody> </table> <p>2. Individual from whom the cash was received</p> <p>a. TIN (SSN/ITIN, EIN, or Other) (Required if known   Part I, Item 6)</p> <table border="1"> <thead> <tr> <th>Name</th> <th>minOccurs</th> <th>maxOccurs</th> <th>Content</th> </tr> </thead> <tbody> <tr> <td>PartyIdentificationNumberText (Item 6)</td> <td>1</td> <td>1</td> <td>Simple</td> </tr> <tr> <td>PartyIdentificationTypeCode (Code 1)</td> <td>1</td> <td>1</td> <td>Simple</td> </tr> </tbody> </table> <p>b. Identifying document (Passport, Driver's License/State ID, etc.) (Required if known   Part I, Item 14)</p> <table border="1"> <thead> <tr> <th>Name</th> <th>minOccurs</th> <th>maxOccurs</th> <th>Content</th> </tr> </thead> <tbody> <tr> <td>OtherIssuerStateText (Item 14b*)</td> <td>0</td> <td>1</td> <td>Simple</td> </tr> <tr> <td>PartyIdentificationNumberText (Item 14c)</td> <td>0</td> <td>1</td> <td>Simple</td> </tr> <tr> <td>PartyIdentificationTypeCode (Item 14a**) (type code)</td> <td>1</td> <td>1</td> <td>Simple</td> </tr> </tbody> </table> <p><i>**Although the element references "State" in the title, this element may contain the country code or state/province/territory code (US, CA, MX only).</i>  <i>**If the identification number and/or the "issued by" contains an entry, then the type of alien identification number (Passport, Driver's License/State ID, etc.) must be specified. If the ID type is Other, and the number and/or issued by is not known/not applicable, then the OtherIssuerStateText and/or PartyIdentificationNumberText element(s) need not be recorded.</i></p> <p>3. Person on whose behalf transaction conducted</p> <p>a. TIN (SSN/ITIN) (Required if known   Part II, Item 19)</p> <table border="1"> <thead> <tr> <th>Name</th> <th>minOccurs</th> <th>maxOccurs</th> <th>Content</th> </tr> </thead> <tbody> <tr> <td>PartyIdentificationNumberText (Item 19)</td> <td>1</td> <td>1</td> <td>Simple</td> </tr> <tr> <td>PartyIdentificationTypeCode (Code 1)</td> <td>1</td> <td>1</td> <td>Simple</td> </tr> </tbody> </table> <p>b. TIN (EIN) (Required if known   Part II, Item 19)</p> <table border="1"> <thead> <tr> <th>Name</th> <th>minOccurs</th> <th>maxOccurs</th> <th>Content</th> </tr> </thead> <tbody> <tr> <td>PartyIdentificationNumberText (Item 19)</td> <td>1</td> <td>1</td> <td>Simple</td> </tr> <tr> <td>PartyIdentificationTypeCode (Item 2)</td> <td>1</td> <td>1</td> <td>Simple</td> </tr> </tbody> </table> <p>c. Alien identification (Passport, Driver's License/State ID, etc.) (Required if known   Part II, Item 27)</p> <table border="1"> <thead> <tr> <th>Name</th> <th>minOccurs</th> <th>maxOccurs</th> <th>Content</th> </tr> </thead> <tbody> <tr> <td>OtherIssuerStateText (Item 27b*)</td> <td>0</td> <td>1</td> <td>Simple</td> </tr> </tbody> </table>						Name	minOccurs	maxOccurs	Content	PartyIdentificationNumberText	1	1	Simple	PartyIdentificationTypeCode (Code 28)	1	1	Simple	Name	minOccurs	maxOccurs	Content	PartyIdentificationNumberText	1	1	Simple	PartyIdentificationTypeCode (Code 2)	1	1	Simple	Name	minOccurs	maxOccurs	Content	PartyIdentificationNumberText (Item 6)	1	1	Simple	PartyIdentificationTypeCode (Code 1)	1	1	Simple	Name	minOccurs	maxOccurs	Content	OtherIssuerStateText (Item 14b*)	0	1	Simple	PartyIdentificationNumberText (Item 14c)	0	1	Simple	PartyIdentificationTypeCode (Item 14a**) (type code)	1	1	Simple	Name	minOccurs	maxOccurs	Content	PartyIdentificationNumberText (Item 19)	1	1	Simple	PartyIdentificationTypeCode (Code 1)	1	1	Simple	Name	minOccurs	maxOccurs	Content	PartyIdentificationNumberText (Item 19)	1	1	Simple	PartyIdentificationTypeCode (Item 2)	1	1	Simple	Name	minOccurs	maxOccurs	Content	OtherIssuerStateText (Item 27b*)	0	1	Simple
Name	minOccurs	maxOccurs	Content																																																																																						
PartyIdentificationNumberText	1	1	Simple																																																																																						
PartyIdentificationTypeCode (Code 28)	1	1	Simple																																																																																						
Name	minOccurs	maxOccurs	Content																																																																																						
PartyIdentificationNumberText	1	1	Simple																																																																																						
PartyIdentificationTypeCode (Code 2)	1	1	Simple																																																																																						
Name	minOccurs	maxOccurs	Content																																																																																						
PartyIdentificationNumberText (Item 6)	1	1	Simple																																																																																						
PartyIdentificationTypeCode (Code 1)	1	1	Simple																																																																																						
Name	minOccurs	maxOccurs	Content																																																																																						
OtherIssuerStateText (Item 14b*)	0	1	Simple																																																																																						
PartyIdentificationNumberText (Item 14c)	0	1	Simple																																																																																						
PartyIdentificationTypeCode (Item 14a**) (type code)	1	1	Simple																																																																																						
Name	minOccurs	maxOccurs	Content																																																																																						
PartyIdentificationNumberText (Item 19)	1	1	Simple																																																																																						
PartyIdentificationTypeCode (Code 1)	1	1	Simple																																																																																						
Name	minOccurs	maxOccurs	Content																																																																																						
PartyIdentificationNumberText (Item 19)	1	1	Simple																																																																																						
PartyIdentificationTypeCode (Item 2)	1	1	Simple																																																																																						
Name	minOccurs	maxOccurs	Content																																																																																						
OtherIssuerStateText (Item 27b*)	0	1	Simple																																																																																						

Element Name:	PartyIdentification	minOccurs:	0	maxOccurs:	3																								
	PartyIdentificationNumberText (Item 27c)		0	1	Simple																								
	PartyIdentificationTypeCode (Item 27a)** (type code)		1	1	Simple																								
	<p><i>*Although the element references "State" in the title, this element may contain the country code or state/province/territory code (US, CA, MX only).</i></p> <p><i>**If the alien identification number and/or the "issued by" contains an entry, then the type of alien identification number (Passport, Driver's License/State ID, etc.) must be specified.</i></p> <p>4. Business that received cash</p> <p>a. Employer Identification number (Required if known   Part IV, Item 36)</p> <table border="1"> <thead> <tr> <th>Name</th> <th>minOccurs</th> <th>maxOccurs</th> <th>Content</th> </tr> </thead> <tbody> <tr> <td>PartyIdentificationNumberText (Item 36)</td> <td>1</td> <td>1</td> <td>Simple</td> </tr> <tr> <td>PartyIdentificationTypeCode (Code 2)</td> <td>1</td> <td>1</td> <td>Simple</td> </tr> </tbody> </table> <p>b. Social security number (Required if known   Part IV, Item 36)</p> <table border="1"> <thead> <tr> <th>Name</th> <th>minOccurs</th> <th>maxOccurs</th> <th>Content</th> </tr> </thead> <tbody> <tr> <td>PartyIdentificationNumberText (Item 19)</td> <td>1</td> <td>1</td> <td>Simple</td> </tr> <tr> <td>PartyIdentificationTypeCode (Item 2)</td> <td>1</td> <td>1</td> <td>Simple</td> </tr> </tbody> </table>					Name	minOccurs	maxOccurs	Content	PartyIdentificationNumberText (Item 36)	1	1	Simple	PartyIdentificationTypeCode (Code 2)	1	1	Simple	Name	minOccurs	maxOccurs	Content	PartyIdentificationNumberText (Item 19)	1	1	Simple	PartyIdentificationTypeCode (Item 2)	1	1	Simple
Name	minOccurs	maxOccurs	Content																										
PartyIdentificationNumberText (Item 36)	1	1	Simple																										
PartyIdentificationTypeCode (Code 2)	1	1	Simple																										
Name	minOccurs	maxOccurs	Content																										
PartyIdentificationNumberText (Item 19)	1	1	Simple																										
PartyIdentificationTypeCode (Item 2)	1	1	Simple																										
Attribute(s)	<p>The following attributes must be recorded for this element:</p> <table border="1"> <thead> <tr> <th>Name</th> <th>Description</th> </tr> </thead> <tbody> <tr> <td>SeqNum</td> <td>The value recorded for this attribute must be numeric and unique. It may contain any numeric value up to 19 characters in length.</td> </tr> </tbody> </table>					Name	Description	SeqNum	The value recorded for this attribute must be numeric and unique. It may contain any numeric value up to 19 characters in length.																				
Name	Description																												
SeqNum	The value recorded for this attribute must be numeric and unique. It may contain any numeric value up to 19 characters in length.																												
Parent Element:	Party																												
Element Restriction(s):	<p>Required. This element must be recorded for the following party types (activity level):</p> <table border="1"> <thead> <tr> <th>Party type</th> <th>TCC (min-max)</th> <th>TIN (min-max)</th> <th>Form of ID (min-max)</th> </tr> </thead> <tbody> <tr> <td>Transmitter</td> <td>1-1</td> <td>1-1</td> <td>n/a</td> </tr> <tr> <td>Individual from whom the cash was received</td> <td>n/a</td> <td>0-1</td> <td>0-1</td> </tr> <tr> <td>Person on whose behalf transaction conducted</td> <td>n/a</td> <td>0-2</td> <td>0-1</td> </tr> <tr> <td>Business that received cash*</td> <td>n/a</td> <td>1-2</td> <td>n/a</td> </tr> </tbody> </table> <p><i>*The EIN and/or the SSN/ITIN must be provided for the Business that received cash.</i></p>					Party type	TCC (min-max)	TIN (min-max)	Form of ID (min-max)	Transmitter	1-1	1-1	n/a	Individual from whom the cash was received	n/a	0-1	0-1	Person on whose behalf transaction conducted	n/a	0-2	0-1	Business that received cash*	n/a	1-2	n/a				
Party type	TCC (min-max)	TIN (min-max)	Form of ID (min-max)																										
Transmitter	1-1	1-1	n/a																										
Individual from whom the cash was received	n/a	0-1	0-1																										
Person on whose behalf transaction conducted	n/a	0-2	0-1																										
Business that received cash*	n/a	1-2	n/a																										
Value Restriction(s):	n/a																												
Remarks:	<p>The batch submission will be <b>rejected</b> if any of the following conditions are true:</p> <ul style="list-style-type: none"> <li>The element is recorded for an inappropriate party type (see Element Restrictions for more information).</li> <li>The element is missing a "SeqNum" attribute.</li> <li>The element contains a "SeqNum" attribute with a duplicate or invalid value.</li> </ul> <p>The batch submission will be <b>accepted with warning</b> if any of the following conditions are true:</p> <ul style="list-style-type: none"> <li>The element is not recorded for the: <ul style="list-style-type: none"> <li>Transmitter EIN and/or TCC</li> <li>Business that received cash EIN (Item 36) and SSN (Item 36) (Note: At least one is required).</li> </ul> </li> </ul>																												
Example:	<p>(Person on whose behalf transaction conducted: SSN/ITIN, EIN, and Alien Identification)</p> <pre>&lt;fc2:PartyIdentification SeqNum="70"&gt;   &lt;fc2:PartyIdentificationNumberText&gt;565898523&lt;/fc2:PartyIdentificationNumberText&gt;   &lt;fc2:PartyIdentificationTypeCode&gt;1&lt;/fc2:PartyIdentificationTypeCode&gt;</pre>																												

Element Name:	PartyIdentification	minOccurs:	0	maxOccurs:	3
	<pre> &lt;/fc2:PartyIdentification&gt; &lt;fc2:PartyIdentification SeqNum="71"&gt;   &lt;fc2:PartyIdentificationNumberText&gt;554123985&lt;/fc2:PartyIdentificationNumberText&gt;   &lt;fc2:PartyIdentificationTypeCode&gt;2&lt;/fc2:PartyIdentificationTypeCode&gt; &lt;/fc2:PartyIdentification&gt; &lt;fc2:PartyIdentification SeqNum="72"&gt;   &lt;fc2:OtherIssuerStateText&gt;VA&lt;/fc2:OtherIssuerStateText&gt;   &lt;fc2:PartyIdentificationNumberText&gt;5326547&lt;/fc2:PartyIdentificationNumberText&gt;   &lt;fc2:PartyIdentificationTypeCode&gt;999&lt;/fc2:PartyIdentificationTypeCode&gt; &lt;/fc2:PartyIdentification&gt; </pre>				

Element Name:	OtherIssuerStateText	minOccurs:	0	maxOccurs:	1
Description:	<p>Identification issuing by state/country/U.S. Territory (code). This element identifies the country or the U.S., Canadian, or Mexican state/province/territory the identification was issued by or in. This element corresponds with the following item(s):</p> <ul style="list-style-type: none"> <li>• Individual from whom the cash was received: <ul style="list-style-type: none"> <li>○ 14b. Issued by</li> </ul> </li> <li>• Person on whose behalf transaction conducted: <ul style="list-style-type: none"> <li>○ 27b. Issued by</li> </ul> </li> </ul> <p><i>Please refer to Attachment C for instructions on completing Items 14 and 27.</i></p>				
Attribute(s)	n/a				
Parent Element:	PartyIdentification				
Element Restriction(s):	<p>Record this element for the following party types when the following conditions are true; otherwise, do not record this element:</p> <ul style="list-style-type: none"> <li>• The Individual from whom the cash was received identifying document (Item 14) is being recorded.</li> <li>• The Person on whose behalf transaction conducted alien identification (Item 27) is being recorded.</li> </ul>				
Value Restriction(s):	<p>The value provided must conform to the following requirements:</p> <ul style="list-style-type: none"> <li>• 2-3 alpha character entry.</li> <li>• Country codes (including U.S. Territory codes) must adhere to the two-letter country codes found in ISO 3166-2.</li> <li>• United States State/Territory codes must adhere to the two-letter codes used by the United States Postal Service as documented in ISO 3166-2:US when the country is equal to US or a U.S. Territory.</li> <li>• Canadian province/territory codes must conform to ISO 3166-2:CA when the country is equal to CA.</li> <li>• Mexican state/federal district codes must adhere to the standards of ISO 3166-2:MX when the country is equal to MX.</li> </ul>				
Remarks:	<p>The batch submission will be <u>rejected</u> if any of the following conditions are true:</p> <ul style="list-style-type: none"> <li>• The element is recorded for an inappropriate party type (see Element Restrictions for more information).</li> </ul> <p>The batch submission will be <u>accepted with warning</u> if any of the following conditions are true:</p> <ul style="list-style-type: none"> <li>• The element is not recorded or does not contain a value and the PartyIdentificationTypeCode is equal to 5 (Driver's License/State ID), 6 (Passport), or 7 (Alien registration).</li> <li>• The element is recorded or contains a value and the PartyIdentificationTypeCode is NOT equal to 5 (Driver's License/State ID), 6 (Passport), 7 (Alien registration), or 999 (Other).</li> <li>• The element contains a value that is not a valid country code or a valid state/province/territory code for US, Canada, or Mexico.</li> </ul>				
Example:	<fc2:OtherIssuerStateText>MX</fc2:OtherIssuerStateText>				

Element Name:	PartyIdentificationNumberText	minOccurs:	0	maxOccurs:	1
Description:	<p>Identification number (text). This element identifies the form of identification number associated with the party. This element corresponds with the following item(s):</p> <ul style="list-style-type: none"> <li>• Transmitter                             <ul style="list-style-type: none"> <li>○ Transmitter Control Code (TCC) number (required)</li> <li>○ Taxpayer Identification Number (EIN) number (required)</li> </ul> </li> <li>• Individual from whom the cash was received                             <ul style="list-style-type: none"> <li>○ 6. TIN (SSN/ITIN) number (required if Item 14 is empty; otherwise, record if known)</li> <li>○ 14c. Identifying document (Passport, Driver's License/State ID, etc.) number (required if Item 6 is empty; otherwise, record if known)</li> </ul> </li> <li>• Person on whose behalf transaction conducted                             <ul style="list-style-type: none"> <li>○ 19. TIN (SSN/ITIN) number (record if known)</li> <li>○ 19. TIN (EIN) number (record if known)</li> <li>○ 27c. Alien Identification (Passport, Driver's License/State ID, etc.) number (record if known)</li> </ul> </li> <li>• Business that received cash                             <ul style="list-style-type: none"> <li>○ 36. EIN number (required if Item 36 SSN/ITIN is empty; otherwise, record if known)</li> <li>○ 36. SSN/ITIN number (required if Item 36 EIN is empty; otherwise, record if known)</li> </ul> </li> </ul> <p><i>Please refer to Attachment C - General Instruction 16 "Identifying numbers" and the line item instructions for additional information regarding the above item(s).</i></p>				
Attribute(s)	n/a				
Parent Element:	PartyIdentification				
Element Restriction(s):	Required. This element must be recorded if the parent element is recorded.				
Value Restriction(s):	<p>The value provided must adhere to the following requirements by party type:</p> <ul style="list-style-type: none"> <li>• Transmitter (35)                             <ul style="list-style-type: none"> <li>○ TCC = 8 characters equal to "TBSATEST" (when submitting in the BSA E-Filing User Test System) or "PBSA8180" (when submitting in the BSA E-Filing Production System)</li> <li>○ EIN = 9 numeric characters</li> </ul> </li> <li>• Individual from whom the cash was received (16), Person on whose behalf transaction conducted (23), and Business that received cash (4)                             <ul style="list-style-type: none"> <li>○ EIN or SSN/ITIN = 9 numeric characters</li> <li>○ Identification number (Passport, Driver's License/State ID, etc.) = 22 characters or less</li> </ul> </li> </ul> <p>All identification numbers must be entered as a single alpha/numeric text string without formatting or special characters such as, for example, spaces, hyphens, or periods. Cannot be consecutive string of the same number or an incremental string such as 123456789.</p>				
Remarks:	<p>The batch submission will be <u>accepted with warning</u> if any of the following conditions are true:</p> <ul style="list-style-type: none"> <li>• The value recorded for the TIN (SN/ITIN) of the Individual from whom the cash is an invalid number string.</li> <li>• The value recorded for the EIN and/or SSN/ITIN of the Person on whose behalf transaction conducted is an invalid number string.</li> <li>• The value recorded for the EIN and/or SSN/ITIN of the Business that received cash is an invalid number string.</li> </ul>				
Example:	<fc2:PartyIdentificationNumberText>660623559</fc2:PartyIdentificationNumberText>				

Element Name:	PartyIdentificationTypeCode	minOccurs:	1	maxOccurs:	1
Description:	<p>Identification type (code). This element identifies the type of identification number recorded for the party. This element corresponds with the following item(s):</p> <ul style="list-style-type: none"> <li>• Transmitter                             <ul style="list-style-type: none"> <li>○ Transmitter Control Code (TCC) type</li> <li>○ Taxpayer Identification Number (TIN) type</li> </ul> </li> <li>• Individual from whom the cash was received                             <ul style="list-style-type: none"> <li>○ 6. TIN number type</li> </ul> </li> </ul>				

Element Name:	PartyIdentificationTypeCode	minOccurs:	1	maxOccurs:	1																																																				
	<ul style="list-style-type: none"> <li>o 14a. Identifying document number (Describe ID) type</li> <li>• Person on whose behalf transaction conducted                             <ul style="list-style-type: none"> <li>o 19. TIN number type (type=SSN/ITIN)</li> <li>o 19. TIN number type (type=EIN)</li> <li>o 27a. Alien Identification number (Describe ID) type</li> </ul> </li> <li>• Business that received cash                             <ul style="list-style-type: none"> <li>o 36. EIN number type (type=EIN)</li> <li>o 36. SSN/ITIN number type (Type=SSN/ITIN)</li> </ul> </li> </ul>																																																								
Attribute(s)	n/a																																																								
Parent Element:	PartyIdentification																																																								
Element Restriction(s):	Required. This element must be recorded when the parent element is recorded.																																																								
Value Restriction(s):	<p>The value provided must conform to the following requirements: Identify the identification type by recording the appropriate code from the list below (by party type):</p> <div style="background-color: #e1f5fe; padding: 10px; text-align: center;"> <p><b>Activity party type code definitions</b></p> <p>35 = Transmitter   16 = Individual from whom the cash was received                      23 = Person on whose behalf transaction conducted   4 = Business that received cash</p> </div> <table border="1" style="width: 100%; border-collapse: collapse; text-align: center;"> <thead> <tr> <th rowspan="2">Code</th> <th rowspan="2">Description</th> <th colspan="4">Party Type (Code)</th> </tr> <tr> <th>35</th> <th>16</th> <th>23</th> <th>4</th> </tr> </thead> <tbody> <tr> <td>28</td> <td>Transmitter Control Code (TCC)</td> <td>•</td> <td></td> <td></td> <td></td> </tr> <tr> <td>2</td> <td>Employer Identification Number (EIN)</td> <td>•</td> <td>•</td> <td>•</td> <td>•</td> </tr> <tr> <td>1</td> <td>Social Security Number (SSN) / Individual Taxpayer Identification Number (ITIN)</td> <td></td> <td>•</td> <td>•</td> <td>•</td> </tr> <tr> <td>5</td> <td>Driver's License/State ID</td> <td></td> <td>•</td> <td>•</td> <td></td> </tr> <tr> <td>6</td> <td>Passport</td> <td></td> <td>•</td> <td>•</td> <td></td> </tr> <tr> <td>7</td> <td>Alien registration</td> <td></td> <td>•</td> <td>•</td> <td></td> </tr> <tr> <td>999</td> <td>Other Identification</td> <td></td> <td>•</td> <td>•</td> <td></td> </tr> </tbody> </table>					Code	Description	Party Type (Code)				35	16	23	4	28	Transmitter Control Code (TCC)	•				2	Employer Identification Number (EIN)	•	•	•	•	1	Social Security Number (SSN) / Individual Taxpayer Identification Number (ITIN)		•	•	•	5	Driver's License/State ID		•	•		6	Passport		•	•		7	Alien registration		•	•		999	Other Identification		•	•	
Code	Description	Party Type (Code)																																																							
		35	16	23	4																																																				
28	Transmitter Control Code (TCC)	•																																																							
2	Employer Identification Number (EIN)	•	•	•	•																																																				
1	Social Security Number (SSN) / Individual Taxpayer Identification Number (ITIN)		•	•	•																																																				
5	Driver's License/State ID		•	•																																																					
6	Passport		•	•																																																					
7	Alien registration		•	•																																																					
999	Other Identification		•	•																																																					
Remarks:	<p>The batch submission will be <u>rejected</u> if any of the following conditions are true:</p> <ul style="list-style-type: none"> <li>• The element is not recorded.</li> <li>• The element contains a value not equal to one of the approved codes listed above.</li> <li>• The element is recorded but without a value (i.e. the value is null).</li> <li>• The element contains a value that is not valid for the associated party type.</li> <li>• The element contains a value that has already been recorded for the same party type.</li> </ul>																																																								
Example:	<fc2:PartyIdentificationTypeCode>999</fc2:PartyIdentificationTypeCode>																																																								

#### 4.5.5. PartyOccupationBusiness Elements

Element Name:	PartyOccupationBusiness	minOccurs:	0	maxOccurs:	1
Description:	<p>Occupation or type of business (header). This is the container for information about the occupation or type of business of the party.</p> <p>The following sub-element is associated with this element:</p> <div style="background-color: #e1f5fe; padding: 10px; text-align: center;"> <p><b>Activity party type code definitions</b></p> <p>16 = Individual from whom the cash was received                      23 = Person on whose behalf transaction conducted   4 = Business that received cash</p> </div> <ol style="list-style-type: none"> <li>1. Individual from whom the cash was received: Occupation, profession, or business (If known   Part I, Item 13)</li> </ol>				

Element Name:	PartyOccupationBusiness	minOccurs:	0	maxOccurs:	1	
	Name		minOccurs	maxOccurs	Content	
	OccupationBusinessText (Item 13)		1	1	Simple	
	2. Person on whose behalf transaction conducted: Occupation, profession, or business (If known   Part II, Item 22)					
	Name		minOccurs	maxOccurs	Content	
	OccupationBusinessText (Item 22)		1	1	Simple	
	3. Business that received cash: Nature of your business (If known   Part IV, Item 41)					
	Name		minOccurs	maxOccurs	Content	
	OccupationBusinessText (Item 41)		1	1	Simple	
	Attribute(s)	The following attributes must be recorded for this element:				
		Name		Description		
	SeqNum	The value recorded for this attribute must be numeric and unique. It may contain any numeric value up to 19 characters in length.				
Parent Element:	Party					
Element Restriction(s):	Record this element when the occupation/type of business is known for the above party types; otherwise, do not record this element.					
Value Restriction(s):	n/a					
Remarks:	<p>The batch submission will be <u>rejected</u> if any of the following conditions are true:</p> <ul style="list-style-type: none"> <li>The element is recorded for an inappropriate party type (see Element Restrictions for more information).</li> <li>The element is recorded for a valid party type, but all sub-elements are missing.</li> <li>The element is missing a "SeqNum" attribute.</li> <li>The element contains a "SeqNum" attribute with a duplicate or invalid value.</li> </ul>					
Example:	<pre>&lt;fc2:PartyOccupationBusiness SeqNum="40"&gt;   &lt;fc2:OccupationBusinessText&gt;Mechanic&lt;/fc2:OccupationBusinessText&gt; &lt;/fc2:PartyOccupationBusiness&gt;</pre>					

Element Name:	OccupationBusinessText	minOccurs:	1	maxOccurs:	1
Description:	<p>Occupation or type of business (description). This element identifies the description of the occupation, profession, or type of business of the party. This element corresponds with the following item(s):</p> <ul style="list-style-type: none"> <li>Individual from whom the cash was received: <ul style="list-style-type: none"> <li>13. Occupation, profession, or business</li> </ul> </li> <li>Person on whose behalf transaction conducted: <ul style="list-style-type: none"> <li>22. Occupation, profession, or business</li> </ul> </li> <li>Business that received cash: <ul style="list-style-type: none"> <li>41. Nature of your business</li> </ul> </li> </ul> <p><i>Please refer to Attachment C line item instructions for additional information regarding the above items.</i></p>				
Attribute(s)	n/a				
Parent Element:	PartyOccupationBusiness				
Element Restriction(s):	Required. This element must be recorded when the parent element is recorded.				
Value Restriction(s):	The value provided must conform to the following requirements: 25 characters or less for Item 13 and 30 characters or less for Items 22 and 41.				

Element Name:	OccupationBusinessText	minOccurs:	1	maxOccurs:	1
Remarks:	The batch submission will be <u>rejected</u> if any of the following conditions are true: <ul style="list-style-type: none"> <li>The element is not recorded.</li> </ul>				
Example:	<fc2:OccupationBusinessText>Mechanic</fc2:OccupationBusinessText>				

#### 4.6. CurrencyTransactionActivity

Element Name:	CurrencyTransactionActivity	minOccurs:	1	maxOccurs:	1																												
Description:	<p>Transaction details (header). This is the container for information about the transaction details and method of payment associated with the FinCEN Form 8300.</p> <p>The following sub-element is associated with this element:</p> <table border="1"> <thead> <tr> <th>Name</th> <th>minOccurs</th> <th>maxOccurs</th> <th>Category</th> </tr> </thead> <tbody> <tr> <td>InstallmentPaymentOtherIndicator (Item 30)</td> <td>0</td> <td>1</td> <td>Simple</td> </tr> <tr> <td>Total100DollarBillInAmountText (Item 32 - \$100 bills)</td> <td>0</td> <td>1</td> <td>Simple</td> </tr> <tr> <td>TotalCashInReceiveAmountText (Item 29)</td> <td>1</td> <td>1</td> <td>Simple</td> </tr> <tr> <td>TotalPriceAmountText (Item 31)</td> <td>0</td> <td>1</td> <td>Simple</td> </tr> <tr> <td>TransactionDateText (Item 28)</td> <td>1</td> <td>1</td> <td>Simple</td> </tr> <tr> <td>CurrencyTransactionActivityDetail (Items 32-34)</td> <td>2</td> <td>9</td> <td>Complex</td> </tr> </tbody> </table> <p>This element corresponds with the following item(s):</p> <ul style="list-style-type: none"> <li>Part III – Description of Transaction and Method of Payments                             <ul style="list-style-type: none"> <li>Item 28. Date cash received</li> <li>Item 29. Total cash received</li> <li>Item 30. If cash was received in more than on payment</li> <li>Item 31. Total price if different from Item 29</li> <li>Item 32. Amount in \$100 bills or higher</li> </ul> </li> </ul> <p><i>Please refer to Attachment C line item instructions for additional information regarding the above items.</i></p>					Name	minOccurs	maxOccurs	Category	InstallmentPaymentOtherIndicator (Item 30)	0	1	Simple	Total100DollarBillInAmountText (Item 32 - \$100 bills)	0	1	Simple	TotalCashInReceiveAmountText (Item 29)	1	1	Simple	TotalPriceAmountText (Item 31)	0	1	Simple	TransactionDateText (Item 28)	1	1	Simple	CurrencyTransactionActivityDetail (Items 32-34)	2	9	Complex
Name	minOccurs	maxOccurs	Category																														
InstallmentPaymentOtherIndicator (Item 30)	0	1	Simple																														
Total100DollarBillInAmountText (Item 32 - \$100 bills)	0	1	Simple																														
TotalCashInReceiveAmountText (Item 29)	1	1	Simple																														
TotalPriceAmountText (Item 31)	0	1	Simple																														
TransactionDateText (Item 28)	1	1	Simple																														
CurrencyTransactionActivityDetail (Items 32-34)	2	9	Complex																														
Attribute(s)	<p>The following attributes must be recorded for this element:</p> <table border="1"> <thead> <tr> <th>Name</th> <th>Description</th> </tr> </thead> <tbody> <tr> <td>SeqNum</td> <td>The value recorded for this attribute must be numeric and unique. It may contain any numeric value up to 19 characters in length.</td> </tr> </tbody> </table>					Name	Description	SeqNum	The value recorded for this attribute must be numeric and unique. It may contain any numeric value up to 19 characters in length.																								
Name	Description																																
SeqNum	The value recorded for this attribute must be numeric and unique. It may contain any numeric value up to 19 characters in length.																																
Parent Element:	Activity																																
Element Restriction(s):	Required. This element must be recorded.																																
Value Restriction(s):	n/a																																
Remarks:	<p>The batch submission will be <u>rejected</u> if any of the following conditions are true:</p> <ul style="list-style-type: none"> <li>The element is not recorded.</li> <li>The element is missing a "SeqNum" attribute.</li> <li>The element contains a "SeqNum" attribute with a duplicate or invalid value.</li> </ul>																																
Example:	<pre>&lt;fc2:CurrencyTransactionActivity SeqNum="50"&gt;   &lt;fc2:InstallmentPaymentOtherIndicator&gt;Y&lt;/fc2:InstallmentPaymentOtherIndicator&gt;   &lt;fc2:Total100DollarBillInAmountText&gt;300&lt;/fc2:Total100DollarBillInAmountText&gt;   &lt;fc2:TotalCashInReceiveAmountText&gt;25000&lt;/fc2:TotalCashInReceiveAmountText&gt;   &lt;fc2:TotalPriceAmountText&gt;27000&lt;/fc2:TotalPriceAmountText&gt;   &lt;fc2:TransactionDateText&gt;20180918&lt;/fc2:TransactionDateText&gt;   &lt;fc2:CurrencyTransactionActivityDetail SeqNum="51"&gt;     &lt;fc2:DetailTransactionAmountText&gt;1000&lt;/fc2:DetailTransactionAmountText&gt;     &lt;fc2:InstrumentProductServiceTypeCode&gt;35&lt;/fc2:InstrumentProductServiceTypeCode&gt;   &lt;/fc2:CurrencyTransactionActivityDetail&gt; &lt;/fc2:CurrencyTransactionActivityDetail SeqNum="54"&gt;</pre>																																

Element Name:	CurrencyTransactionActivity	minOccurs:	1	maxOccurs:	1
	<fc2:CurrencyTransactionActivityDetailTypeCode>1</fc2:CurrencyTransactionActivityDetailTypeCode> </fc2:CurrencyTransactionActivityDetailTypeCode> ... </fc2:CurrencyTransactionActivity>				

Element Name:	InstallmentPaymentOtherIndicator	minOccurs:	0	maxOccurs:	1
Description:	Installment payment (indicator). This element indicates that the total cash amount was received in more than one payment, such as installment payments or payments on related transactions. This element corresponds with the following item(s): <ul style="list-style-type: none"> <li>Item 30. If cash was received in more than one payment</li> </ul>				
Attribute(s)	n/a				
Parent Element:	CurrencyTransactionActivity				
Element Restriction(s):	Record this element when the total cash amount was received in more than one payment; otherwise, do not record this element.				
Value Restriction(s):	The value provided must conform to the following requirements: Must equal Y				
Remarks:	The batch submission will be <u>rejected</u> if any of the following conditions are true: <ul style="list-style-type: none"> <li>The element is not null and contains a value not equal to "Y"</li> <li></li> </ul>				
Example:	<fc2:InstallmentPaymentOtherIndicator>Y</fc2:InstallmentPaymentOtherIndicator>				

Element Name:	Total100DollarBillInAmountText	minOccurs:	0	maxOccurs:	1
Description:	U.S. currency in \$100 bills or higher (amount). This element identifies the U.S. currency amount of \$100 bills (or higher) involved in the FinCEN Form 8300. This element corresponds with the following item(s): <ul style="list-style-type: none"> <li>Item 32. Amount in \$100 bills or higher</li> </ul> <i>Please refer to Attachment C General Instruction 14 "Monetary amounts" and the line item instructions for additional information regarding the above item.</i>				
Attribute(s)	n/a				
Parent Element:	CurrencyTransactionActivity				
Element Restriction(s):	Record this element when the cash received as part of the FinCEN Form 8300 involves U.S. currency in the form of \$100 bills (or higher) and the total amount in \$100 bills (or higher) is known; otherwise, do not record this element.				
Value Restriction(s):	The value provided must conform to the following requirements: 3-10 numeric characters (without leading zeros) denominated in whole U.S. Dollars.				
Remarks:	The batch submission will be <u>accepted with warning</u> if any of the following conditions are true: <ul style="list-style-type: none"> <li>The value recorded contains leading zeros, contains non-numeric characters, or is equal to "0."</li> </ul>				
Example:	<fc2:Total100DollarBillInAmountText>300</fc2:Total100DollarBillInAmountText>				

Element Name:	TotalCashInReceiveAmountText	minOccurs:	1	maxOccurs:	1
Description:	Total cash received (amount). This element identifies total dollar amount of cash received in whole U.S. dollars related to the FinCEN Form 8300. This element corresponds with the following item(s): <ul style="list-style-type: none"> <li>Item 29. Total cash received</li> </ul> <i>Please refer to Attachment C General Instruction 14 "Monetary amounts" and the line item instructions for additional information regarding the above item.</i>				



Element Name:	TotalCashInReceiveAmountText	minOccurs:	1	maxOccurs:	1
Attribute(s)	n/a				
Parent Element:	CurrencyTransactionActivity				
Element Restriction(s):	Required. This element must be recorded.				
Value Restriction(s):	The value provided must conform to the following requirements: 1-10 numeric characters (without leading zeros) denominated in whole U.S. Dollars.				
Remarks:	<p>The batch submission will be <u>rejected</u> if any of the following conditions are true:</p> <ul style="list-style-type: none"> <li>The element is not recorded.</li> </ul> <p>The batch submission will be <u>accepted with warning</u> if any of the following conditions are true:</p> <ul style="list-style-type: none"> <li>The element is recorded but the value is null.</li> <li>The value recorded contains leading zeros, contains non-numeric characters, or is equal to "0."</li> </ul>				
Example:	<fc2:TotalCashInReceiveAmountText>25000</fc2:TotalCashInReceiveAmountText>				

Element Name:	TotalPriceAmountText	minOccurs:	0	maxOccurs:	1
Description:	<p>Total price when different from total cash (amount). This element identifies the total price (n whole U.S. dollars) of the property, services, amount of cash exchanged, etc. (such as the total cost of a vehicle purchased, cost of catering service, exchange of currency) if different from the total cash received amount.</p> <p>This element corresponds with the following item(s):</p> <ul style="list-style-type: none"> <li>Item 31. Total price if different from item 29</li> </ul> <p><i>Please refer to Attachment C General Instruction 14 "Monetary amounts" and the line item instructions for additional information regarding the above item.</i></p>				
Attribute(s)	n/a				
Parent Element:	CurrencyTransactionActivity				
Element Restriction(s):	Record this element when the total price of the property, services, amount of cash exchanged, etc., is different from the total cash received; otherwise, do not record this element.				
Value Restriction(s):	The value provided must conform to the following requirements: 1-10 numeric characters (without leading zeros) denominated in whole U.S. Dollars.				
Remarks:	<p>The batch submission will be <u>accepted with warning</u> if any of the following conditions are true:</p> <ul style="list-style-type: none"> <li>The value recorded contains leading zeros, contains non-numeric characters, is equal to "0", or is equal to the Item 29 Total cash received amount (TotalCashInReceiveAmountText).</li> </ul>				
Example:	<fc2:TotalPriceAmountText>27000</fc2:TotalPriceAmountText>				

Element Name:	TransactionDateText	minOccurs:	1	maxOccurs:	1
Description:	<p>Date cash received (date). This element identifies the date upon which cash was received. In the event that cash was received in more than one payment, this element should identify the date at which time payment received caused the combined amount to exceed \$10,000.</p> <p>This element corresponds with the following item(s):</p> <ul style="list-style-type: none"> <li>Item 28. Date cash received</li> </ul> <p><i>Please refer to Attachment C for additional information regarding the above item(s).</i></p>				
Attribute(s)	n/a				
Parent Element:	CurrencyTransactionActivity				
Element Restriction(s):	Required. This element must be recorded.				
Value Restriction(s):	The value provided must conform to the following requirements: 8 numeric characters in the format YYYYMMDD where YYYY = year, MM = month, and DD = day. Single digit days or months must be prefaced by a zero.				
Remarks:	<p>The batch submission will be <u>rejected</u> if any of the following conditions are true:</p> <ul style="list-style-type: none"> <li>The element is not recorded.</li> <li>The element is recorded but does not contain a value.</li> </ul>				

Element Name:	TransactionDateText	minOccurs:	1	maxOccurs:	1
	<ul style="list-style-type: none"> <li>The value recorded for the element is not in the required format (YYYYMMDD). The batch submission will be <u>accepted with warning</u> if any of the following conditions are true:                             <ul style="list-style-type: none"> <li>The value recorded is greater than the date of signature (FilingDateText).</li> </ul> </li> </ul>				
Example:	<fc2:TransactionDateText>20180918</fc2:TransactionDateText>				

Element Name:	CurrencyTransactionActivityDetail	See <i>CurrencyTransactionActivityDetail Elements</i> for details.
---------------	-----------------------------------	--

### 4.6.1. CurrencyTransactionActivityDetail

Element Name:	CurrencyTransactionActivityDetail	minOccurs:	2	maxOccurs:	9																																																																				
Description:	<p>Sub-total amount(s) and type(s) of transaction details (header). This is the container for information about the sub-total amount(s) and type(s) of transaction associated with the FinCEN Form 8300.</p> <p>The following sub-element is associated with this element:</p> <table border="1"> <thead> <tr> <th>Name</th> <th>minOccurs</th> <th>maxOccurs</th> <th>Category</th> </tr> </thead> <tbody> <tr> <td>CurrencyTransactionActivityDetailTypeCode</td> <td>0</td> <td>1</td> <td>Simple</td> </tr> <tr> <td>DetailTransactionAmountText</td> <td>0</td> <td>1</td> <td>Simple</td> </tr> <tr> <td>DetailTransactionDescription</td> <td>0</td> <td>1</td> <td>Simple</td> </tr> <tr> <td>InstrumentProductServiceTypeCode</td> <td>0</td> <td>1</td> <td>Simple</td> </tr> <tr> <td>IssuerNameText</td> <td>0</td> <td>1</td> <td>Simple</td> </tr> <tr> <td>OtherForeignCurrencyCountryText</td> <td>0</td> <td>1</td> <td>Simple</td> </tr> </tbody> </table> <p>This element corresponds with the following item(s):</p> <ol style="list-style-type: none"> <li>Item 32a-f/country/issuer description. Amount of cash received (in U.S. dollar equivalent)   Required (at least one, but not more than six, must be recorded per FinCEN Form 8300)                     <table border="1"> <thead> <tr> <th>Name</th> <th>minOccurs</th> <th>maxOccurs</th> <th>Category</th> </tr> </thead> <tbody> <tr> <td><i>CurrencyTransactionActivityDetail</i></td> <td>1</td> <td>6</td> <td>Complex</td> </tr> <tr> <td>DetailTransactionAmountText (32a-f, amount)</td> <td>1</td> <td>1</td> <td>Simple</td> </tr> <tr> <td>InstrumentProductServiceTypeCode (32a-f, type)*</td> <td>1</td> <td>1</td> <td>Simple</td> </tr> <tr> <td>IssuerNameText (32 Issuer name/serial number)**</td> <td>0</td> <td>1</td> <td>Simple</td> </tr> <tr> <td>OtherForeignCurrencyCountryText (32 Country)***</td> <td>0</td> <td>1</td> <td>Simple</td> </tr> </tbody> </table> <p><i>*Duplicate InstrumentProductServiceTypeCode values are not permitted within the FinCEN Form 8300.</i>  <i>**If the InstrumentProductServiceTypeCode value is associated with 32c (Cashier's checks), 32d (Money orders), 32e (Bank drafts), or 32f Traveler's checks), then a description of the issuer's name(s) and serial number(s) of the monetary instruments must be recorded when known in the IssuerNameText element; otherwise, do not record this element.</i>  <i>***If the InstrumentProductServiceTypeCode value is associated with 32b (Foreign currency), then the country code associated with the foreign currency must be recorded when known in the OtherForeignCurrencyCountryText element; otherwise, do not record this element.</i></p> </li> <li>Item 33a-j. Type of transaction &amp; 34. Property/Service description.   Required (at least one, but not more than three, must be recorded per FinCEN Form 8300)                     <table border="1"> <thead> <tr> <th>Name</th> <th>minOccurs</th> <th>maxOccurs</th> <th>Category</th> </tr> </thead> <tbody> <tr> <td><i>CurrencyTransactionActivityDetail</i></td> <td>1</td> <td>3</td> <td>Complex</td> </tr> <tr> <td>CurrencyTransactionActivityDetailTypeCode (33a-j)*</td> <td>1</td> <td>1</td> <td>Simple</td> </tr> <tr> <td>DetailTransactionDescription (34 description)**</td> <td>0</td> <td>1</td> <td>Simple</td> </tr> </tbody> </table> <p><i>*Duplicate CurrencyTransactionActivityDetailTypeCode values are not permitted within the FinCEN Form 8300.</i></p> </li> </ol>					Name	minOccurs	maxOccurs	Category	CurrencyTransactionActivityDetailTypeCode	0	1	Simple	DetailTransactionAmountText	0	1	Simple	DetailTransactionDescription	0	1	Simple	InstrumentProductServiceTypeCode	0	1	Simple	IssuerNameText	0	1	Simple	OtherForeignCurrencyCountryText	0	1	Simple	Name	minOccurs	maxOccurs	Category	<i>CurrencyTransactionActivityDetail</i>	1	6	Complex	DetailTransactionAmountText (32a-f, amount)	1	1	Simple	InstrumentProductServiceTypeCode (32a-f, type)*	1	1	Simple	IssuerNameText (32 Issuer name/serial number)**	0	1	Simple	OtherForeignCurrencyCountryText (32 Country)***	0	1	Simple	Name	minOccurs	maxOccurs	Category	<i>CurrencyTransactionActivityDetail</i>	1	3	Complex	CurrencyTransactionActivityDetailTypeCode (33a-j)*	1	1	Simple	DetailTransactionDescription (34 description)**	0	1	Simple
Name	minOccurs	maxOccurs	Category																																																																						
CurrencyTransactionActivityDetailTypeCode	0	1	Simple																																																																						
DetailTransactionAmountText	0	1	Simple																																																																						
DetailTransactionDescription	0	1	Simple																																																																						
InstrumentProductServiceTypeCode	0	1	Simple																																																																						
IssuerNameText	0	1	Simple																																																																						
OtherForeignCurrencyCountryText	0	1	Simple																																																																						
Name	minOccurs	maxOccurs	Category																																																																						
<i>CurrencyTransactionActivityDetail</i>	1	6	Complex																																																																						
DetailTransactionAmountText (32a-f, amount)	1	1	Simple																																																																						
InstrumentProductServiceTypeCode (32a-f, type)*	1	1	Simple																																																																						
IssuerNameText (32 Issuer name/serial number)**	0	1	Simple																																																																						
OtherForeignCurrencyCountryText (32 Country)***	0	1	Simple																																																																						
Name	minOccurs	maxOccurs	Category																																																																						
<i>CurrencyTransactionActivityDetail</i>	1	3	Complex																																																																						
CurrencyTransactionActivityDetailTypeCode (33a-j)*	1	1	Simple																																																																						
DetailTransactionDescription (34 description)**	0	1	Simple																																																																						

Element Name:	CurrencyTransactionActivityDetail	minOccurs:	2	maxOccurs:	9						
	<p><b>**If the CurrencyTransactionActivityDetailTypeCode value is associated with 33j (Other), then the DetailTransactionDescription must be recorded; otherwise, record this element if known.</b></p> <p>Please refer to Attachment C for additional information regarding the above item(s).</p>										
Attribute(s)	<p>The following attributes must be recorded for this element:</p> <table border="1"> <thead> <tr> <th>Name</th> <th>Description</th> </tr> </thead> <tbody> <tr> <td>SeqNum</td> <td>The value recorded for this attribute must be numeric and unique. It may contain any numeric value up to 19 characters in length.</td> </tr> </tbody> </table>					Name	Description	SeqNum	The value recorded for this attribute must be numeric and unique. It may contain any numeric value up to 19 characters in length.		
Name	Description										
SeqNum	The value recorded for this attribute must be numeric and unique. It may contain any numeric value up to 19 characters in length.										
Parent Element:	CurrencyTransactionActivity										
Element Restriction(s):	<p>Required. This element must be recorded at a minimum of two occurrences and a maximum of 9 occurrences per FinCEN Form 8300.</p> <p>The following table describes the minimum and maximum reporting requirements per party type:</p> <table border="1"> <thead> <tr> <th>Item(s)</th> <th>min-max</th> </tr> </thead> <tbody> <tr> <td>Item 32. Amount of cash received (a-f/country/issuer description)</td> <td>1-6</td> </tr> <tr> <td>Item 33. Type of transaction / Item 34. Description</td> <td>1-3</td> </tr> </tbody> </table>					Item(s)	min-max	Item 32. Amount of cash received (a-f/country/issuer description)	1-6	Item 33. Type of transaction / Item 34. Description	1-3
Item(s)	min-max										
Item 32. Amount of cash received (a-f/country/issuer description)	1-6										
Item 33. Type of transaction / Item 34. Description	1-3										
Value Restriction(s):	n/a										
Remarks:	<p>The batch submission will be <u>rejected</u> if any of the following conditions are true:</p> <ul style="list-style-type: none"> <li>The element is recorded but all sub-elements are missing.</li> <li>The element is missing a "SeqNum" attribute.</li> <li>The element contains a "SeqNum" attribute with a duplicate or invalid value.</li> <li>The FinCEN Form 8300 does not include at least one occurrence of the CurrencyTransactionActivityDetail element where the: <ul style="list-style-type: none"> <li>InstrumentProductServiceTypeCode sub-element (associated with Item 32) is recorded with a valid value.</li> <li>CurrencyTransactionActivityDetailTypeCode sub-element (associated with Item 33) is recorded with a valid value.</li> </ul> </li> <li>The FinCEN Form 8300 includes multiple occurrences of the CurrencyTransactionActivityDetail element where the: <ul style="list-style-type: none"> <li>InstrumentProductServiceTypeCode sub-element (associated with Item 32) is recorded with a duplicate value.</li> <li>CurrencyTransactionActivityDetailTypeCode sub-element (associated with Item 33) is recorded with a duplicate value.</li> </ul> </li> </ul> <p>The batch submission will be <u>accepted with warning</u> if any of the following conditions are true:</p> <ul style="list-style-type: none"> <li>The FinCEN Form 8300 includes more than 3 occurrences of the CurrencyTransactionActivityDetail element where the CurrencyTransactionActivityDetailTypeCode sub-element (associated with Item 33) is recorded with a valid value.</li> </ul>										
Example:	<pre>&lt;fc2:CurrencyTransactionActivity SeqNum="50"&gt;   &lt;fc2:InstallmentPaymentOtherIndicator&gt;Y&lt;/fc2:InstallmentPaymentOtherIndicator&gt;   &lt;fc2:Total100DollarBillInAmountText&gt;300&lt;/fc2:Total100DollarBillInAmountText&gt;   &lt;fc2:TotalCashInReceiveAmountText&gt;25000&lt;/fc2:TotalCashInReceiveAmountText&gt;   &lt;fc2:TotalPriceAmountText&gt;27000&lt;/fc2:TotalPriceAmountText&gt;   &lt;fc2:TransactionDateText&gt;20180918&lt;/fc2:TransactionDateText&gt;   &lt;fc2:CurrencyTransactionActivityDetail SeqNum="51"&gt;     &lt;fc2:DetailTransactionAmountText&gt;1000&lt;/fc2:DetailTransactionAmountText&gt;     &lt;fc2:InstrumentProductServiceTypeCode&gt;35&lt;/fc2:InstrumentProductServiceTypeCode&gt;   &lt;/fc2:CurrencyTransactionActivityDetail&gt;   &lt;fc2:CurrencyTransactionActivityDetail SeqNum="52"&gt;     &lt;fc2:DetailTransactionAmountText&gt;4000&lt;/fc2:DetailTransactionAmountText&gt;     &lt;fc2:InstrumentProductServiceTypeCode&gt;16&lt;/fc2:InstrumentProductServiceTypeCode&gt;   &lt;/fc2:CurrencyTransactionActivityDetail&gt; &lt;/fc2:CurrencyTransactionActivity&gt;</pre>										

Element Name:	CurrencyTransactionActivityDetail	minOccurs:	2	maxOccurs:	9
	<pre> &lt;fc2:OtherForeignCurrencyCountryText&gt;GB&lt;/fc2:OtherForeignCurrencyCountryText&gt; &lt;/fc2:CurrencyTransactionActivityDetail&gt; &lt;fc2:CurrencyTransactionActivityDetail SeqNum="53"&gt;   &lt;fc2:DetailTransactionAmountText&gt;20000&lt;/fc2:DetailTransactionAmountText&gt;   &lt;fc2:InstrumentProductServiceTypeCode&gt;34&lt;/fc2:InstrumentProductServiceTypeCode&gt; &lt;/fc2:CurrencyTransactionActivityDetail&gt; &lt;fc2:CurrencyTransactionActivityDetail SeqNum="54"&gt;   &lt;fc2:CurrencyTransactionActivityDetailTypeCode&gt;1&lt;/fc2:CurrencyTransactionActivityDetailTypeCode&gt; &lt;/fc2:CurrencyTransactionActivityDetail&gt; &lt;fc2:CurrencyTransactionActivityDetail SeqNum="55"&gt;   &lt;fc2:CurrencyTransactionActivityDetailTypeCode&gt;2&lt;/fc2:CurrencyTransactionActivityDetailTypeCode&gt; &lt;/fc2:CurrencyTransactionActivityDetail&gt; &lt;fc2:CurrencyTransactionActivityDetail SeqNum="56"&gt;   &lt;fc2:CurrencyTransactionActivityDetailTypeCode&gt;999&lt;/fc2:CurrencyTransactionActivityDetailTypeCode&gt;   &lt;fc2:DetailTransactionDescription&gt;Other property/service description&lt;/fc2:DetailTransactionDescription&gt; &lt;/fc2:CurrencyTransactionActivityDetail&gt; &lt;/fc2:CurrencyTransactionActivity&gt; </pre>				

Element Name:	CurrencyTransactionActivityDetailTypeCode	minOccurs:	0	maxOccurs:	1																						
Description:	<p>Type of transaction (code). This element identifies the type of transaction associated with the FinCEN Form 8300.</p> <p>This element corresponds with the following item(s):</p> <ul style="list-style-type: none"> <li>Item 33a-j. Type of transaction</li> </ul> <p><i>Please refer to Attachment C line item instructions for additional information regarding the above item.</i></p>																										
Attribute(s)	n/a																										
Parent Element:	CurrencyTransactionActivityDetail																										
Element Restriction(s):	<p>Record this element when identifying the type of transaction associated with the FinCEN Form 8300; otherwise, do not record this element.</p> <p><b>IMPORTANT:</b> At least one occurrence of the CurrencyTransactionActivityDetail parent element must include the CurrencyTransactionActivityDetailTypeCode element where the type of transaction is identified. No more than 3 transaction types may be recorded for a single FinCEN Form 8300.</p>																										
Value Restriction(s):	<p>The value provided must conform to the following requirements:</p> <table border="1"> <thead> <tr> <th>Code</th> <th>Description</th> </tr> </thead> <tbody> <tr> <td>1</td> <td>Personal property purchased</td> </tr> <tr> <td>2</td> <td>Real property purchased</td> </tr> <tr> <td>3</td> <td>Personal services provided</td> </tr> <tr> <td>4</td> <td>Business services provided</td> </tr> <tr> <td>5</td> <td>Intangible property purchased</td> </tr> <tr> <td>6</td> <td>Debt obligations paid</td> </tr> <tr> <td>7</td> <td>Exchange of cash</td> </tr> <tr> <td>8</td> <td>Escrow or trust funds</td> </tr> <tr> <td>9</td> <td>Bail received by clerks</td> </tr> <tr> <td>999</td> <td>Other</td> </tr> </tbody> </table>					Code	Description	1	Personal property purchased	2	Real property purchased	3	Personal services provided	4	Business services provided	5	Intangible property purchased	6	Debt obligations paid	7	Exchange of cash	8	Escrow or trust funds	9	Bail received by clerks	999	Other
Code	Description																										
1	Personal property purchased																										
2	Real property purchased																										
3	Personal services provided																										
4	Business services provided																										
5	Intangible property purchased																										
6	Debt obligations paid																										
7	Exchange of cash																										
8	Escrow or trust funds																										
9	Bail received by clerks																										
999	Other																										

Element Name:	CurrencyTransactionActivityDetailTypeCode	minOccurs:	0	maxOccurs:	1
Remarks:	The batch submission will be <b>rejected</b> if any of the following conditions are true: <ul style="list-style-type: none"> <li>The element is recorded and the value is null/does not equal a valid code.</li> </ul>				
Example:	<pre>&lt;fc2:CurrencyTransactionActivityDetail SeqNum="55"&gt;   &lt;fc2:CurrencyTransactionActivityDetailTypeCode&gt;2&lt;/fc2:CurrencyTransactionActivityDetailTypeCode&gt; &lt;/fc2:CurrencyTransactionActivityDetail&gt; &lt;fc2:CurrencyTransactionActivityDetail SeqNum="56"&gt;   &lt;fc2:CurrencyTransactionActivityDetailTypeCode&gt;999&lt;/fc2:CurrencyTransactionActivityDetailTypeCode&gt;   &lt;fc2:DetailTransactionDescription&gt;Other property/service description&lt;/fc2:DetailTransactionDescription&gt; &lt;/fc2:CurrencyTransactionActivityDetail&gt;</pre>				

Element Name:	DetailTransactionAmountText	minOccurs:	0	maxOccurs:	1
Description:	<p>Detailed transaction sub-total (amount). This element identifies the sub-total amount of cash received associated with the FinCEN Form 8300.</p> <p>This element corresponds with the following item(s):</p> <ul style="list-style-type: none"> <li>Item 32a-f. Amount of cash received</li> </ul> <p><i>Please refer to Attachment C General Instruction 17 "Monetary amounts" and the line item instructions for additional information regarding the above item.</i></p>				
Attribute(s)	n/a				
Parent Element:	CurrencyTransactionActivityDetail				
Element Restriction(s):	<p>Record this element when identifying the sub-total amount associated with the FinCEN Form 8300; otherwise, do not record this element.</p> <p><b>IMPORTANT:</b> At least one occurrence of the <i>CurrencyTransactionActivityDetail</i> parent element must include the <i>DetailTransactionAmountText</i> element where the sub-total cash amount received is identified. No more than 6 sub-total amounts may be recorded for a single FinCEN Form 8300.</p>				
Value Restriction(s):	The value provided must conform to the following requirements: 1-10 numeric characters (without leading zeros) denominated in whole U.S. Dollars.				
Remarks:	<p>The batch submission will be <b>rejected</b> if any of the following conditions are true:</p> <ul style="list-style-type: none"> <li>The element is not recorded or does not contain a value and the <i>InstrumentProductServiceTypeCode</i> element is recorded for the parent element.</li> </ul> <p>The batch submission will be <b>accepted with warning</b> if any of the following conditions are true:</p> <ul style="list-style-type: none"> <li>The value recorded contains leading zeros, contains non-numeric characters, or is equal to "0."</li> </ul>				
Example:	<pre>&lt;fc2:CurrencyTransactionActivityDetail SeqNum="51"&gt;   &lt;fc2:DetailTransactionAmountText&gt;1000&lt;/fc2:DetailTransactionAmountText&gt;   &lt;fc2:InstrumentProductServiceTypeCode&gt;35&lt;/fc2:InstrumentProductServiceTypeCode&gt; &lt;/fc2:CurrencyTransactionActivityDetail&gt; &lt;fc2:CurrencyTransactionActivityDetail SeqNum="52"&gt;   &lt;fc2:DetailTransactionAmountText&gt;4000&lt;/fc2:DetailTransactionAmountText&gt;   &lt;fc2:InstrumentProductServiceTypeCode&gt;16&lt;/fc2:InstrumentProductServiceTypeCode&gt;   &lt;fc2:OtherForeignCurrencyCountryText&gt;GB&lt;/fc2:OtherForeignCurrencyCountryText&gt; &lt;/fc2:CurrencyTransactionActivityDetail&gt;</pre>				

Element Name:	DetailTransactionDescription	minOccurs:	0	maxOccurs:	1
Description:	<p>Type of transaction description (text). This element identifies the specific description of the property or service recorded for the type of transaction in Item 33.</p> <p>This element corresponds with the following item(s):</p> <ul style="list-style-type: none"> <li>Item 34. Specific description of property or service shown in Item 33. Give serial or registration number, address, docket number, etc.</li> </ul>				

Element Name:	DetailTransactionDescription	minOccurs:	0	maxOccurs:	1
	<i>Please refer to Attachment C for additional information regarding the above item(s).</i>				
Attribute(s)	n/a				
Parent Element:	CurrencyTransactionActivityDetail				
Element Restriction(s):	Record this element when identifying the specific description of the property or service recorded for the type of transaction in Item 33; otherwise, do not record this element. <i>IMPORTANT: If the type of transaction is associated with Item 33j (Other), then the DetailTransactionDescription element must be recorded with the specific description of the other property or service transaction type; otherwise, a description (if known) may be provided for all other types of transactions recorded.</i>				
Value Restriction(s):	The value provided must conform to the following requirements: 120 characters or less				
Remarks:	The batch submission will be <u>accepted with warning</u> if any of the following conditions are true: <ul style="list-style-type: none"> <li>The element is not recorded or does not contain a value and the type of transaction for Item 33 is associated with "Other".</li> </ul>				
Example:	<pre>&lt;fc2:CurrencyTransactionActivityDetail SeqNum="56"&gt;   &lt;fc2:CurrencyTransactionActivityDetailTypeCode&gt;7&lt;/fc2:CurrencyTransactionActivityDetailTypeCode&gt;   &lt;fc2:DetailTransactionDescription&gt;Other property/service description&lt;/fc2:DetailTransactionDescription&gt; &lt;/fc2:CurrencyTransactionActivityDetail&gt;</pre>				

Element Name:	InstrumentProductServiceTypeCode	minOccurs:	0	maxOccurs:	1														
Description:	Type of cash received (code). This element identifies the type of cash received associated with the Item 32a-f amount recorded for the FinCEN Form 8300. This element corresponds with the following item(s): <ul style="list-style-type: none"> <li>Item 32a-f. Amount of cash received (type)</li> </ul>																		
Attribute(s)	n/a																		
Parent Element:	CurrencyTransactionActivityDetail																		
Element Restriction(s):	Record this element when identifying the type of cash received associated with the Item 32a-f amount recorded for the FinCEN Form 8300; otherwise, do not record this element. <i>IMPORTANT: If the DetailTransactionAmountText element is recorded, then the InstrumentProductServiceTypeCode element must also be recorded to identify the type of cash received.</i>																		
Value Restriction(s):	The value provided must conform to the following requirements:																		
	<table border="1"> <thead> <tr> <th>Code</th> <th>Description</th> </tr> </thead> <tbody> <tr> <td>35</td> <td>U.S. currency</td> </tr> <tr> <td>16</td> <td>Foreign currency</td> </tr> <tr> <td>39</td> <td>Cashier's check(s)</td> </tr> <tr> <td>26</td> <td>Money order(s)</td> </tr> <tr> <td>40</td> <td>Bank draft(s)</td> </tr> <tr> <td>34</td> <td>Traveler's check(s)</td> </tr> </tbody> </table>					Code	Description	35	U.S. currency	16	Foreign currency	39	Cashier's check(s)	26	Money order(s)	40	Bank draft(s)	34	Traveler's check(s)
Code	Description																		
35	U.S. currency																		
16	Foreign currency																		
39	Cashier's check(s)																		
26	Money order(s)																		
40	Bank draft(s)																		
34	Traveler's check(s)																		
Remarks:	The batch submission will be <u>rejected</u> if any of the following conditions are true: <ul style="list-style-type: none"> <li>The element is recorded and the value is null/does not equal a valid code.</li> <li>The element is not recorded but the DetailTransactionAmountText element is recorded for the parent element.</li> </ul>																		
Example:	<pre>&lt;fc2:CurrencyTransactionActivityDetail SeqNum="51"&gt;   &lt;fc2:DetailTransactionAmountText&gt;1000&lt;/fc2:DetailTransactionAmountText&gt;   &lt;fc2:InstrumentProductServiceTypeCode&gt;35&lt;/fc2:InstrumentProductServiceTypeCode&gt; &lt;/fc2:CurrencyTransactionActivityDetail&gt;</pre>																		

Element Name:	InstrumentProductServiceTypeCode	minOccurs:	0	maxOccurs:	1
	<pre>&lt;fc2:CurrencyTransactionActivityDetail SeqNum="52"&gt;   &lt;fc2:DetailTransactionAmountText&gt;4000&lt;/fc2:DetailTransactionAmountText&gt;   &lt;fc2:InstrumentProductServiceTypeCode&gt;16&lt;/fc2:InstrumentProductServiceTypeCode&gt;   &lt;fc2:OtherForeignCurrencyCountryText&gt;GB&lt;/fc2:OtherForeignCurrencyCountryText&gt; &lt;/fc2:CurrencyTransactionActivityDetail&gt;</pre>				

Element Name:	IssuerNameText	minOccurs:	0	maxOccurs:	1
Description:	<p>Issuer name / serial number description (text). This element identifies the issuer's name(s) and serial number(s) of the monetary instruments(s) recorded (Items 32c-f, if any).</p> <p>This element corresponds with the following item(s):</p> <ul style="list-style-type: none"> <li>Item 32. Issuer's name(s) and serial number(s) of the monetary instruments(s)</li> </ul> <p><i>Please refer to Attachment C line item instructions for additional information regarding the above item(s).</i></p>				
Attribute(s)	n/a				
Parent Element:	CurrencyTransactionActivityDetail				
Element Restriction(s):	<p>Record this element when identifying the issuers name(s) and serial number(s) of the monetary instruments(s) recorded (Items 32c-f, if any); otherwise, do not record this element.</p> <p><b>IMPORTANT:</b> <i>If the type of cash received is not equal to 32c-f, then the IssuerNameText element should not be recorded.</i></p>				
Value Restriction(s):	The value provided must conform to the following requirements: 40 characters or less				
Remarks:	<p>The batch submission will be <u>accepted with warning</u> if any of the following conditions are true:</p> <ul style="list-style-type: none"> <li>The element is recorded with a value and the Item 32 Type of cash received is not associated with Cashier's check(s), Money order(s), Bank draft(s), or Traveler's check(s).</li> </ul>				
Example:	<pre>&lt;fc2:CurrencyTransactionActivityDetail SeqNum="45"&gt;   &lt;fc2:DetailTransactionAmountText&gt;20000&lt;/fc2:DetailTransactionAmountText&gt;   &lt;fc2:InstrumentProductServiceTypeCode&gt;34&lt;/fc2:InstrumentProductServiceTypeCode&gt;   &lt;fc2:IssuerNameText&gt;Traveler's check issuer description&lt;/fc2:IssuerNameText&gt; &lt;/fc2:CurrencyTransactionActivityDetail&gt;</pre>				

Element Name:	OtherForeignCurrencyCountryText	minOccurs:	0	maxOccurs:	1
Description:	<p>Foreign currency country (code). This element identifies the country associated with the Item 32b foreign currency recorded for the FinCEN Form 8300.</p> <p>This element corresponds with the following item(s):</p> <ul style="list-style-type: none"> <li>Item 32. Country</li> </ul> <p><i>Please refer to Attachment C line item instructions for additional information regarding the above item(s).</i></p>				
Attribute(s)	n/a				
Parent Element:	CurrencyTransactionActivityDetail				
Element Restriction(s):	<p>Record this element when identifying the country associated with the Item 32b foreign currency (if recorded) for the FinCEN Form 8300; otherwise, do not record this element.</p> <p><b>IMPORTANT:</b> <i>If the type of cash received is not equal to 32b, then the OtherForeignCurrencyCountryText element should not be recorded.</i></p>				
Value Restriction(s):	The value provided must conform to the following requirements: 2-character alpha code associated with a foreign country not equal to U.S. or a U.S. Territory. Country codes must adhere to the two-letter country codes found in ISO 3166-2.				
Remarks:	<p>The batch submission will be <u>accepted with warning</u> if any of the following conditions are true:</p> <ul style="list-style-type: none"> <li>The element is not recorded (or does not contain a value) and the Item 32 Type of cash received is associated with Foreign currency.</li> <li>The element is recorded with a valid country code and the Item 32 Type of cash received is NOT associated with Foreign currency.</li> <li>The value recorded is not a valid country code.</li> <li>The value recorded is equal to US or a US Territory.</li> </ul>				

Element Name:	OtherForeignCurrencyCountryText	minOccurs:	0	maxOccurs:	1
Example:	<pre>&lt;fc2:CurrencyTransactionActivityDetail SeqNum="44"&gt;   &lt;fc2:DetailTransactionAmountText&gt;4000&lt;/fc2:DetailTransactionAmountText&gt;   &lt;fc2:InstrumentProductServiceTypeCode&gt;16&lt;/fc2:InstrumentProductServiceTypeCode&gt;   &lt;fc2:OtherForeignCurrencyCountryText&gt;GB&lt;/fc2:OtherForeignCurrencyCountryText&gt; &lt;/fc2:CurrencyTransactionActivityDetail&gt;</pre>				

### 4.7. ActivityNarrativeInformation Elements

Element Name:	ActivityNarrativeInformation	minOccurs:	0	maxOccurs:	1												
Description:	<p>Comments (header). This element is the container for any comments or clarification information associated with the FinCEN Form 8300.</p> <p>The following sub-elements are associated with this element:</p> <table border="1"> <thead> <tr> <th>Name</th> <th>minOccurs</th> <th>maxOccurs</th> <th>Category</th> </tr> </thead> <tbody> <tr> <td>ActivityNarrativeSequenceNumber</td> <td>1</td> <td>1</td> <td>Simple</td> </tr> <tr> <td>ActivityNarrativeText</td> <td>1</td> <td>1</td> <td>Simple</td> </tr> </tbody> </table> <p>This element corresponds with the following item(s):</p> <ul style="list-style-type: none"> <li>FinCEN Form 8300 Report – Comments</li> </ul> <p><i>Please refer to Attachment C for additional information regarding the above item(s).</i></p>					Name	minOccurs	maxOccurs	Category	ActivityNarrativeSequenceNumber	1	1	Simple	ActivityNarrativeText	1	1	Simple
Name	minOccurs	maxOccurs	Category														
ActivityNarrativeSequenceNumber	1	1	Simple														
ActivityNarrativeText	1	1	Simple														
Attribute(s)	<p>The following attributes must be recorded for this element:</p> <table border="1"> <thead> <tr> <th>Name</th> <th>Description</th> </tr> </thead> <tbody> <tr> <td>SeqNum</td> <td>The value recorded for this attribute must be numeric and unique. It may contain any numeric value up to 19 characters in length.</td> </tr> </tbody> </table>					Name	Description	SeqNum	The value recorded for this attribute must be numeric and unique. It may contain any numeric value up to 19 characters in length.								
Name	Description																
SeqNum	The value recorded for this attribute must be numeric and unique. It may contain any numeric value up to 19 characters in length.																
Parent Element:	Activity																
Element Restriction(s):	Record this element if there are comments or clarification information associated with the FinCEN Form 8300; otherwise, do not record this element.																
Value Restriction(s):	n/a																
Remarks:	<p>The batch submission will be <u>rejected</u> if any of the following conditions are true:</p> <ul style="list-style-type: none"> <li>The element is missing a "SeqNum" attribute.</li> <li>The element contains a "SeqNum" attribute with a duplicate or invalid value.</li> </ul>																
Example:	<pre>&lt;fc2:ActivityNarrativeInformation SeqNum="136"&gt;   &lt;fc2:ActivityNarrativeSequenceNumber&gt;1&lt;/fc2:ActivityNarrativeSequenceNumber&gt;   &lt;fc2:ActivityNarrativeText&gt;Comments text here&lt;/fc2:ActivityNarrativeText&gt; &lt;/fc2:ActivityNarrativeInformation&gt;</pre>																

Element Name:	ActivityNarrativeSequenceNumber	minOccurs:	1	maxOccurs:	1
Description:	Comments (sequence number). This element is for FinCEN internal use only. It must be recorded in the event that ActivityNarrativeInformation element is recorded for the FinCEN Form 8300.				
Attribute(s)	n/a				
Parent Element:	ActivityNarrativeInformation				
Element Restriction(s):	Required. This element must be recorded when the parent element is recorded.				
Value Restriction(s):	The value provided must conform to the following requirements: must equal 1				
Remarks:	<p>The batch submission will be <u>rejected</u> if any of the following conditions are true:</p> <ul style="list-style-type: none"> <li>The element is not recorded or does not contain a value.</li> <li>The value recorded is not equal to "1".</li> </ul>				
Example:	<pre>&lt;fc2:ActivityNarrativeSequenceNumber&gt;1&lt;/fc2:ActivityNarrativeSequenceNumber&gt;</pre>				



Element Name:	ActivityNarrativeText	minOccurs:	1	maxOccurs:	1
Description:	Comments. This element records additional filer comments or data associated with the FinCEN Form 8300. It should include any comments or clarifying information associated with any data recorded for Parts I – IV. If Item 1b "Suspicious transaction is reported, explain why the transaction(s) being reported is or are suspicious. If Item 32 "Issuer's name(s) and serial number(s)" is too small to record all names/serial numbers, record the remainder in Comments. The same applies to Item 34 "Specific description of property or service.				
Attribute(s)	n/a				
Parent Element:	ActivityNarrativeInformation				
Element Restriction(s):	Required. This element must be recorded when the parent element is recorded.				
Value Restriction(s):	The value provided must conform to the following requirements: 720 characters or less				
Remarks:	The batch submission will be <u>rejected</u> if any of the following conditions are true: <ul style="list-style-type: none"> <li>The element is not recorded or does not contain a value.</li> </ul>				
Example:	<fc2:ActivityNarrativeText>Text narrative text</fc2:ActivityNarrativeText>				

## 5. Party Elements by Party Type

The <Party> element is comprised of various elements and sub-elements that apply to specific party types (i.e. Transmitter, Individual from whom the cash was received, etc.). The chart below describes at a high level the party elements that apply to each party type.

Activity party type code definitions							
35 = Transmitter   37 = Transmitter Contact   16 = Individual from whom the cash was received							
23 = Person on whose behalf transaction conducted   4 = Business that received cash							
3 = Authorized Official   8 = Contact for Assistance							
Element name	35	37	16	23	4	3	8
<Party SeqNum="">	●	●	●	●	●	●	●
<ActivityPartyTypeCode/>	●	●	●	●	●	●	●
<PartyTypeCode/>				●			
<IndividualBirthDateText/>			●				
<PartyName SeqNum="">	●	●	●	●	●	●	●
<PartyNameTypeCode/>	●	●		●			
<RawEntityIndividualLastName/>			●	●			
<RawIndividualFirstName/>			●	●			
<RawIndividualMiddleName/>			●	●			
<RawIndividualTitleText/>						●	
<RawPartyFullName/>	●	●		●	●		●
</PartyName>	●	●	●	●	●	●	●
<Address SeqNum="">	●		●	●	●		
<RawCityText/>	●		●	●	●		
<RawCountryCodeText/>	●		●	●			
<RawStateCodeText/>	●		●	●	●		
<RawStreetAddress1Text/>	●		●	●	●		
<RawZIPCode/>	●		●	●	●		
</Address>	●		●	●	●		
<PhoneNumber SeqNum="">	●						●
<PhoneNumberText/>	●						●
</PhoneNumber>	●						●
<PartyIdentification SeqNum="">	●		●	●	●		
<OtherIssuerStateText/>			●	●			
<PartyIdentificationNumberText/>	●		●	●	●		
<PartyIdentificationTypeCode/>	●		●	●	●		
</PartyIdentification>	●		●	●	●		
<PartyOccupationBusiness SeqNum="">			●	●	●		
<OccupationBusinessText/>			●	●	●		
</PartyOccupationBusiness>			●	●	●		

## 5.1. Party Record Examples

### 5.1.1. Transmitter

Party Type	Transmitter	minOccurs:	1	maxOccurs:	1
35	<pre> &lt;fc2:Party SeqNum="3"&gt;   &lt;fc2:ActivityPartyTypeCode&gt;35&lt;/fc2:ActivityPartyTypeCode&gt;   &lt;fc2:PartyName SeqNum="4"&gt;     &lt;fc2:PartyNameTypeCode&gt;L&lt;/fc2:PartyNameTypeCode&gt;     &lt;fc2:RawPartyFullName&gt;Transmitter Legal Name&lt;/fc2:RawPartyFullName&gt;   &lt;/fc2:PartyName&gt;   &lt;fc2:Address SeqNum="5"&gt;     &lt;fc2:RawCityText&gt;McLean&lt;/fc2:RawCityText&gt;     &lt;fc2:RawCountryCodeText&gt;US&lt;/fc2:RawCountryCodeText&gt;     &lt;fc2:RawStateCodeText&gt;VA&lt;/fc2:RawStateCodeText&gt;     &lt;fc2:RawStreetAddress1Text&gt;123 Street&lt;/fc2:RawStreetAddress1Text&gt;     &lt;fc2:RawZIPCode&gt;55478&lt;/fc2:RawZIPCode&gt;   &lt;/fc2:Address&gt;   &lt;fc2:PhoneNumber SeqNum="6"&gt;     &lt;fc2:PhoneNumberText&gt;7031231234&lt;/fc2:PhoneNumberText&gt;   &lt;/fc2:PhoneNumber&gt;   &lt;fc2:PartyIdentification SeqNum="7"&gt;     &lt;fc2:PartyIdentificationNumberText&gt;451898562&lt;/fc2:PartyIdentificationNumberText&gt;     &lt;fc2:PartyIdentificationTypeCode&gt;2&lt;/fc2:PartyIdentificationTypeCode&gt;   &lt;/fc2:PartyIdentification&gt;   &lt;fc2:PartyIdentification SeqNum="8"&gt;     &lt;fc2:PartyIdentificationNumberText&gt;PBSA8180&lt;/fc2:PartyIdentificationNumberText&gt;     &lt;fc2:PartyIdentificationTypeCode&gt;28&lt;/fc2:PartyIdentificationTypeCode&gt;   &lt;/fc2:PartyIdentification&gt; &lt;/fc2:Party&gt; </pre>				

### 5.1.2. Transmitter contact

Party Type	Transmitter Contact	minOccurs:	1	maxOccurs:	1
37	<pre> &lt;fc2:Party SeqNum="10"&gt;   &lt;fc2:ActivityPartyTypeCode&gt;37&lt;/fc2:ActivityPartyTypeCode&gt;   &lt;fc2:PartyName SeqNum="11"&gt;     &lt;fc2:PartyNameTypeCode&gt;L&lt;/fc2:PartyNameTypeCode&gt;     &lt;fc2:RawPartyFullName&gt;Transmitter contact legal name&lt;/fc2:RawPartyFullName&gt;   &lt;/fc2:PartyName&gt; &lt;/fc2:Party&gt; </pre>				

### 5.1.3. Individual from whom the cash was received

Party Type	Filing Institution	minOccurs:	1	maxOccurs:	99
16	<pre> &lt;fc2:Party SeqNum="95"&gt;   &lt;fc2:ActivityPartyTypeCode&gt;16&lt;/fc2:ActivityPartyTypeCode&gt;   &lt;fc2:IndividualBirthDateText&gt;19750101&lt;/fc2:IndividualBirthDateText&gt;   &lt;fc2:PartyName SeqNum="96"&gt;     &lt;fc2:RawEntityIndividualLastName&gt;Williams&lt;/fc2:RawEntityIndividualLastName&gt;     &lt;fc2:RawIndividualFirstName&gt;John&lt;/fc2:RawIndividualFirstName&gt;     &lt;fc2:RawIndividualMiddleName&gt;Holmes&lt;/fc2:RawIndividualMiddleName&gt;   &lt;/fc2:PartyName&gt;   &lt;fc2:Address SeqNum="97"&gt;     &lt;fc2:RawCityText&gt;Rockville&lt;/fc2:RawCityText&gt;     &lt;fc2:RawCountryCodeText&gt;US&lt;/fc2:RawCountryCodeText&gt;     &lt;fc2:RawStateCodeText&gt;MD&lt;/fc2:RawStateCodeText&gt;     &lt;fc2:RawStreetAddress1Text&gt;456 Street&lt;/fc2:RawStreetAddress1Text&gt;   &lt;/fc2:Address&gt; &lt;/fc2:Party&gt; </pre>				

Party Type	Filing Institution	minOccurs:	1	maxOccurs:	99
	<pre>                     &lt;fc2:RawZIPCode&gt;254789841 &lt;/fc2:RawZIPCode&gt;                 &lt;/fc2:Address&gt;                 &lt;fc2:PartyIdentification SeqNum="98"&gt;                     &lt;fc2:PartyIdentificationNumberText&gt; 125489563 &lt;/fc2:PartyIdentificationNumberText&gt;                     &lt;fc2:PartyIdentificationTypeCode&gt; 1 &lt;/fc2:PartyIdentificationTypeCode&gt;                 &lt;/fc2:PartyIdentification&gt;                 &lt;fc2:PartyIdentification SeqNum="99"&gt;                     &lt;fc2:OtherIssuerStateText&gt; FL &lt;/fc2:OtherIssuerStateText&gt;                     &lt;fc2:PartyIdentificationNumberText&gt; G459851234 &lt;/fc2:PartyIdentificationNumberText&gt;                     &lt;fc2:PartyIdentificationTypeCode&gt; 5 &lt;/fc2:PartyIdentificationTypeCode&gt;                 &lt;/fc2:PartyIdentification&gt;                 &lt;fc2:PartyOccupationBusiness SeqNum="100"&gt;                     &lt;fc2:OccupationBusinessText&gt; Business description &lt;/fc2:OccupationBusinessText&gt;                 &lt;/fc2:PartyOccupationBusiness&gt;             &lt;/fc2:Party&gt;                     </pre>				

**5.1.4. Person on whose behalf transaction conducted**

Party Type	Designated Contact Office	minOccurs:	0	maxOccurs:	99
23	<pre>                 &lt;fc2:Party SeqNum="253"&gt;                     &lt;fc2:ActivityPartyTypeCode&gt; 23 &lt;/fc2:ActivityPartyTypeCode&gt;                     &lt;fc2:PartyTypeCode&gt; O &lt;/fc2:PartyTypeCode&gt;                     &lt;fc2:PartyName SeqNum="254"&gt;                         &lt;fc2:PartyNameTypeCode&gt; L &lt;/fc2:PartyNameTypeCode&gt;                         &lt;fc2:RawEntityIndividualLastName&gt; Bob's Business &lt;/fc2:RawEntityIndividualLastName&gt;                     &lt;/fc2:PartyName&gt;                     &lt;fc2:PartyName SeqNum="255"&gt;                         &lt;fc2:PartyNameTypeCode&gt; DBA &lt;/fc2:PartyNameTypeCode&gt;                         &lt;fc2:RawPartyFullName&gt; Bobby's Business &lt;/fc2:RawPartyFullName&gt;                     &lt;/fc2:PartyName&gt;                     &lt;fc2:Address SeqNum="256"&gt;                         &lt;fc2:RawCityText&gt; Silver Spring &lt;/fc2:RawCityText&gt;                         &lt;fc2:RawCountryCodeText&gt; US &lt;/fc2:RawCountryCodeText&gt;                         &lt;fc2:RawStateCodeText&gt; MD &lt;/fc2:RawStateCodeText&gt;                         &lt;fc2:RawStreetAddress1Text&gt; 789 Street &lt;/fc2:RawStreetAddress1Text&gt;                         &lt;fc2:RawZIPCode&gt; 54789 &lt;/fc2:RawZIPCode&gt;                     &lt;/fc2:Address&gt;                     &lt;fc2:PartyIdentification SeqNum="257"&gt;                         &lt;fc2:PartyIdentificationNumberText&gt; 565898523 &lt;/fc2:PartyIdentificationNumberText&gt;                         &lt;fc2:PartyIdentificationTypeCode&gt; 1 &lt;/fc2:PartyIdentificationTypeCode&gt;                     &lt;/fc2:PartyIdentification&gt;                     &lt;fc2:PartyIdentification SeqNum="258"&gt;                         &lt;fc2:PartyIdentificationNumberText&gt; 554123985 &lt;/fc2:PartyIdentificationNumberText&gt;                         &lt;fc2:PartyIdentificationTypeCode&gt; 2 &lt;/fc2:PartyIdentificationTypeCode&gt;                     &lt;/fc2:PartyIdentification&gt;                     &lt;fc2:PartyIdentification SeqNum="259"&gt;                         &lt;fc2:OtherIssuerStateText&gt; CA &lt;/fc2:OtherIssuerStateText&gt;                         &lt;fc2:PartyIdentificationNumberText&gt; 5326547 &lt;/fc2:PartyIdentificationNumberText&gt;                         &lt;fc2:PartyIdentificationTypeCode&gt; 999 &lt;/fc2:PartyIdentificationTypeCode&gt;                     &lt;/fc2:PartyIdentification&gt;                     &lt;fc2:PartyOccupationBusiness SeqNum="260"&gt;                         &lt;fc2:OccupationBusinessText&gt; Business description &lt;/fc2:OccupationBusinessText&gt;                     &lt;/fc2:PartyOccupationBusiness&gt;                 &lt;/fc2:Party&gt;                     </pre>				

**5.1.1. Business that received cash**

Party Type	Designated Contact Office	minOccurs:	1	maxOccurs:	1
4	<pre> &lt;fc2:Party SeqNum="36"&gt;   &lt;fc2:ActivityPartyTypeCode&gt;4&lt;/fc2:ActivityPartyTypeCode&gt;   &lt;fc2:PartyName SeqNum="37"&gt;     &lt;fc2:RawPartyFullName&gt;Name of business that received cash&lt;/fc2:RawPartyFullName&gt;   &lt;/fc2:PartyName&gt;   &lt;fc2:Address SeqNum="38"&gt;     &lt;fc2:RawCityText&gt;Richmond&lt;/fc2:RawCityText&gt;     &lt;fc2:RawStateCodeText&gt;VA&lt;/fc2:RawStateCodeText&gt;     &lt;fc2:RawStreetAddress1Text&gt;159 Street&lt;/fc2:RawStreetAddress1Text&gt;     &lt;fc2:RawZIPCode&gt;66589&lt;/fc2:RawZIPCode&gt;   &lt;/fc2:Address&gt;   &lt;fc2:PartyIdentification SeqNum="39"&gt;     &lt;fc2:PartyIdentificationNumberText&gt;565898523&lt;/fc2:PartyIdentificationNumberText&gt;     &lt;fc2:PartyIdentificationTypeCode&gt;2&lt;/fc2:PartyIdentificationTypeCode&gt;   &lt;/fc2:PartyIdentification&gt;   &lt;fc2:PartyIdentification SeqNum="40"&gt;     &lt;fc2:PartyIdentificationNumberText&gt;554123985&lt;/fc2:PartyIdentificationNumberText&gt;     &lt;fc2:PartyIdentificationTypeCode&gt;1&lt;/fc2:PartyIdentificationTypeCode&gt;   &lt;/fc2:PartyIdentification&gt;   &lt;fc2:PartyOccupationBusiness SeqNum="41"&gt;     &lt;fc2:OccupationBusinessText&gt;Business description&lt;/fc2:OccupationBusinessText&gt;   &lt;/fc2:PartyOccupationBusiness&gt; &lt;/fc2:Party&gt; </pre>				

**5.1.1. Authorized official**

Party Type	Designated Contact Office	minOccurs:	0	maxOccurs:	1
3	<pre> &lt;fc2:Party SeqNum="88"&gt;   &lt;fc2:ActivityPartyTypeCode&gt;3&lt;/fc2:ActivityPartyTypeCode&gt;   &lt;fc2:PartyName SeqNum="89"&gt;     &lt;fc2:RawIndividualTitleText&gt;Authorizing person title&lt;/fc2:RawIndividualTitleText&gt;   &lt;/fc2:PartyName&gt; &lt;/fc2:Party&gt; </pre>				

**5.1.1. Contact for assistance**

Party Type	Designated Contact Office	minOccurs:	0	maxOccurs:	1
8	<pre> &lt;fc2:Party SeqNum="174"&gt;   &lt;fc2:ActivityPartyTypeCode&gt;8&lt;/fc2:ActivityPartyTypeCode&gt;   &lt;fc2:PartyName SeqNum="175"&gt;     &lt;fc2:RawPartyFullName&gt;Contact name&lt;/fc2:RawPartyFullName&gt;   &lt;/fc2:PartyName&gt;   &lt;fc2:PhoneNumber SeqNum="176"&gt;     &lt;fc2:PhoneNumberText&gt;4589774512&lt;/fc2:PhoneNumberText&gt;   &lt;/fc2:PhoneNumber&gt; &lt;/fc2:Party&gt; </pre>				

## 6. FinCEN Form 8300 XML Acknowledgement Format

The FinCEN Form 8300 XML batch acknowledgement file defined below is provided in XML format. The acknowledgement file will contain a BSA Identifier and any corresponding acknowledgement errors associated with each FinCEN Form 8300 <Activity> element received in the batch submission. Please visit [https://www.fincen.gov/sites/default/files/schema/base/EFL\\_BatchAcknowledgementSchema.xsd](https://www.fincen.gov/sites/default/files/schema/base/EFL_BatchAcknowledgementSchema.xsd) to access the FinCEN XML 2.0 batch acknowledgement schema file.

### 6.1. XML File Structure

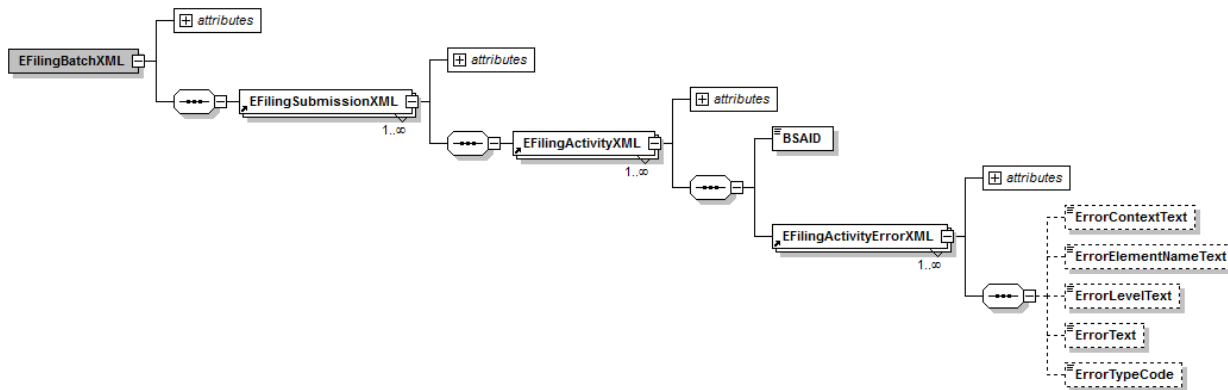

#### 6.1.1. XML declaration/prolog

The XML declaration appears on the first line of the acknowledgement file.

Element Name:	?xml	minOccurs:	1	maxOccurs:	1
Description:	XML declaration/prolog. This is the XML declaration which specifies the XML version and character encoding used in the file.				
Attribute(s):	version. The version number of the XML. The value recorded will be "1.0" encoding. The character encoding used for the XML. The value recorded will be "UTF-8"				
Parent Element:	n/a				
Element Restriction(s)	This declaration will always be recorded on the first line of the file.				
Value Restriction(s):	The value provided will be: <ul style="list-style-type: none"> <li>&lt;?xml version="1.0" encoding="UTF-8"?&gt;</li> </ul>				
Remarks:	none				
Example:	<?xml version="1.0" encoding="UTF-8"?>				

#### 6.1.2. EfilingBatchXML

The <EfilingBatchXML> element is the first element recorded in the file and is considered the root element.

Element Name:	EfilingBatchXML	minOccurs:	1	maxOccurs:	1
Description:	Batch acknowledgement (header). This is the container for the contents of the batch acknowledgement file.				
	This element is parent to the following sub-elements: EfilingSubmissionXML *				
	NOTE: Elements marked with an asterisk * contain sub-elements.				

Attribute(s):	SeqNum (this is a sequential number assigned by FinCEN to identify the corresponding element in the associated batch file) StatusCode (this will have a value of "A" to indicate "Acknowledged")
Parent Element:	n/a (this is the root element in the acknowledgment file)
Element Restriction(s):	This element will always be recorded.
Value Restriction(s):	n/a
Remarks:	n/a
Example:	<EFilingBatchXML SeqNum="1" StatusCode="A">

### 6.1.3. EFilingSubmissionXML

The <EFilingSubmissionXML> element directly follows the <EFilingBatchXML> root element. This element is for FinCEN use only.

Element Name:	EFilingSubmissionXML	minOccurs:	1	maxOccurs:	1
Description:	Submission acknowledgement (header). This is the container for all FinCEN Form 8300 <Activity> elements recorded in the associated batch submission.  This element is parent to the following sub-elements: EFilingActivityXML *  NOTE: Elements marked with an asterisk * contain sub-elements.				
Attribute(s):	xmlns (this will always be www.fincen.gov/base) SeqNum (this is a sequential number assigned by FinCEN to identify the corresponding element in the associated batch file) StatusCode (this will have a value of "A" to indicate "Acknowledged")				
Parent Element:	EFilingBatchXML				
Element Restriction(s):	This element will always be recorded.				
Value Restriction(s):	n/a				
Remarks:	This element is for FinCEN use only.				
Example:	<EFilingSubmissionXML xmlns="www.fincen.gov/base" SeqNum="1" StatusCode="A">				

### 6.1.4. EFilingActivityXML

Each <EFilingActivityXML> element in the batch acknowledgement file corresponds with each FinCEN Form 8300 <Activity> element recorded in the original batch submission along with the sequence number (SeqNum) attribute value.

Element Name:	EFilingActivityXML	minOccurs:	1	maxOccurs:	unbounded
Description:	Activity acknowledgement (header). This is the container for acknowledgement information for each FinCEN Form 8300 <Activity> element recorded in the associated batch submission.  This element is parent to the following sub-elements: BSAID EFilingActivityErrorXML *  NOTE: Elements marked with an asterisk * contain sub-elements.				
Attribute(s):	SeqNum (this sequential number matches the value recorded in the associated batch submission)				

Parent Element:	EfilingSubmissionXML
Value Restriction(s):	n/a
Remarks:	none
Example:	<pre>&lt;EfilingActivityXML SeqNum="1"&gt;   &lt;BSAID&gt;31000055053784&lt;/BSAID&gt;   &lt;EfilingActivityErrorXML SeqNum="1"/&gt; &lt;/EfilingActivityXML&gt;</pre>

Element Name:	BSAID	minOccurs:	1	maxOccurs:	1
Description:	Activity acknowledgement BSA Identifier (text). This element identifies the BSA Identifier (BSA ID) assigned by FinCEN to the FinCEN Form 8300 document.				
Attribute(s):	n/a				
Parent Element:	EfilingActivityXML				
Value Restriction(s):	14 characters (numeric only)				
Remarks:	none				
Example:	<BSAID>31000055053784</BSAID>				

### 6.1.5. EfilingActivityErrorXML

There will be at least one <EfilingActivityErrorXML> element for each <EfilingActivityXML> element in the batch acknowledgement file.

Element Name:	EfilingActivityErrorXML	minOccurs:	1	maxOccurs:	unbounded
Description:	<p>Activity acknowledgement error (header). This is the container for error information generated during processing of the associated batch submission related to the FinCEN Form 8300 activity.</p> <p>This element is parent to the following sub-elements:</p> <ul style="list-style-type: none"> <li>ErrorContextText</li> <li>ErrorElementNameText</li> <li>ErrorLevelText</li> <li>ErrorText</li> <li>ErrorTypeCode</li> </ul>				
Attribute(s):	SeqNum (this is a sequential number assigned by FinCEN)				
Parent Element:	EfilingActivityXML				
Value Restriction(s):	n/a				
Remarks:	If there are no errors identified for the FinCEN Form 8300 activity, then the <EfilingActivityErrorXML> element will be recorded with a self-closing tag (e.g. <EfilingActivityErrorXML SeqNum="1"/>) and this element will not be recorded.				
Example:	<pre>&lt;EfilingActivityErrorXML SeqNum="1"&gt;   &lt;ErrorContextText&gt;EfilingBatchXML/Activity[1]/Party[25]/PartyIdentification[49]/PartyIdentificationNumberText&lt;/ErrorContextText&gt;   &lt;ErrorElementNameText&gt;PartyIdentificationNumberText&lt;/ErrorElementNameText&gt;   &lt;ErrorLevelText&gt;WARN&lt;/ErrorLevelText&gt;   &lt;ErrorText&gt;The value recorded for the EIN or SSN/ITIN is an invalid number string.&lt;/ErrorText&gt;   &lt;ErrorTypeCode&gt;C21&lt;/ErrorTypeCode&gt; &lt;/EfilingActivityErrorXML&gt; &lt;EfilingActivityErrorXML SeqNum="2"&gt;</pre>				



<pre>                 &lt;ErrorContextText&gt;EFilingBatchXML/Activity[1]/Party[78]/PartyName[84]/RawIndividualFirstN                 ame&lt;/ErrorContextText&gt;                 &lt;ErrorElementNameText&gt;RawIndividualFirstName&lt;/ErrorElementNameText&gt;                 &lt;ErrorLevelText&gt;WARN&lt;/ErrorLevelText&gt;                 &lt;ErrorText&gt;The element is not recorded or does not contain a value for an individual Subject                 and unknown is not indicated.&lt;/ErrorText&gt;                 &lt;ErrorTypeCode&gt;C4&lt;/ErrorTypeCode&gt;             &lt;/EFilingActivityErrorXML&gt;             </pre>
---

Element Name:	ErrorContextText	minOccurs:	0	maxOccurs:	1
Description:	Acknowledgement error type (text). This element identifies the element location (within the associated batch submission) that triggered the error by identifying the name and sequence number of the element's <Parent> element.				
Attribute(s):	n/a				
Parent Element:	EFilingActivityErrorXML				
Value Restriction(s):	1-4000 characters				
Remarks:	If there are no errors identified for the FinCEN Form 8300 activity, then the <EFilingActivityErrorXML> element will be recorded with a self-closing tag (e.g. <EFilingActivityErrorXML SeqNum="1"/>) and this element will not be recorded.				
Example:	<ErrorContextText>EFilingBatchXML/Activity[1]/Party[25]/PartyIdentification[49]/PartyIdentificationNumberText</ErrorContextText>				

Element Name:	ErrorElementNameText	minOccurs:	0	maxOccurs:	1
Description:	Element acknowledgement error association (text). This element identifies the element name from the associated batch submission that triggered the error.				
Attribute(s):	n/a				
Parent Element:	EFilingActivityErrorXML				
Value Restriction(s):	1-512 characters				
Remarks:	If there are no errors identified for the FinCEN Form 8300 activity, then the <EFilingActivityErrorXML> element will be recorded with a self-closing tag (e.g. <EFilingActivityErrorXML SeqNum="1"/>) and this element will not be recorded.				
Example:	<ErrorElementNameText>PartyIdentificationNumberText</ErrorElementNameText>				

Element Name:	ErrorLevelText	minOccurs:	0	maxOccurs:	1
Description:	Acknowledgement error severity level (text). This element identifies the level of severity associated with the error.				
Attribute(s):	n/a				
Parent Element:	EFilingActivityErrorXML				
Value Restriction(s):	1-50 characters				
Remarks:	If there are no errors identified for the FinCEN Form 8300 activity, then the <EFilingActivityErrorXML> element will be recorded with a self-closing tag (e.g. <EFilingActivityErrorXML SeqNum="1"/>) and this element will not be recorded.				
Example:	<ErrorLevelText>WARN</ErrorLevelText>				

Element Name:	ErrorText	minOccurs:	0	maxOccurs:	1
Description:	Acknowledgement error description (text). This element identifies the description of the error.				

Attribute(s):	n/a
Parent Element:	EfilingActivityErrorXML
Value Restriction(s):	1-525 characters
Remarks:	If there are no errors identified for the FinCEN Form 8300 activity, then the <EfilingActivityErrorXML> element will be recorded with a self-closing tag (e.g. <EfilingActivityErrorXML SeqNum="1"/>) and this element will not be recorded.
Example:	<ErrorText>The value recorded for the EIN or SSN/ITIN is an invalid number string.</ErrorText>

Element Name:	ErrorTypeCode	minOccurs:	0	maxOccurs:	1
Description:	Acknowledgement error type (code). This element identifies the code associated with the error.				
Attribute(s):	n/a				
Parent Element:	EfilingActivityErrorXML				
Value Restriction(s):	1-50 characters				
Remarks:	If there are no errors identified for the FinCEN Form 8300 activity, then the <EfilingActivityErrorXML> element will be recorded with a self-closing tag (e.g. <EfilingActivityErrorXML SeqNum="1"/>) and this element will not be recorded.				
Example:	<ErrorTypeCode>C4</ErrorTypeCode>				

## 6.2. Acknowledgement XML Example

The following is a sample FinCEN Form 8300 acknowledgement XML generated by FinCEN and delivered to the batch filer.

File type	FinCEN Form 8300 XML Batch Acknowledgement (Sample)
Example:	<pre> &lt;?xml version="1.0" encoding="UTF-8"?&gt; &lt;EfilingBatchXML xmlns="www.fincen.gov/base" SeqNum="1" StatusCode="A"&gt;   &lt;EfilingSubmissionXML SeqNum="1" StatusCode="A"&gt;     &lt;EfilingActivityXML SeqNum="1"&gt;       &lt;BSAID&gt;31000055053784&lt;/BSAID&gt;       &lt;EfilingActivityErrorXML SeqNum="1"&gt;         &lt;ErrorContextText&gt;EfilingBatchXML/Activity[1]/Party[25]/PartyIdentification[49]/OtherIssuerStateText&lt;/ErrorContextText&gt;         &lt;ErrorElementNameText&gt;PartyIdentificationNumberText&lt;/ErrorElementNameText&gt;         &lt;ErrorLevelText&gt;WARN&lt;/ErrorLevelText&gt;         &lt;ErrorText&gt; The element is not recorded or does not contain a value and the PartyIdentificationTypeCode is equal to 5 (Driver's License/State ID), 6 (Passport), 7 (Alien registration), or 999 (Other).&lt;/ErrorText&gt;         &lt;ErrorTypeCode&gt;P05&lt;/ErrorTypeCode&gt;       &lt;/EfilingActivityErrorXML&gt;     &lt;/EfilingActivityXML&gt;     &lt;EfilingActivityErrorXML SeqNum="2"&gt;       &lt;ErrorContextText&gt;EfilingBatchXML/Activity[1]/Party[78]/PartyName[84]/RawEntityIndividualLastName&lt;/ErrorContextText&gt;       &lt;ErrorElementNameText&gt;RawIndividualFirstName&lt;/ErrorElementNameText&gt;       &lt;ErrorLevelText&gt;WARN&lt;/ErrorLevelText&gt;       &lt;ErrorText&gt;The legal name is not recorded.&lt;/ErrorText&gt;       &lt;ErrorTypeCode&gt;P03&lt;/ErrorTypeCode&gt;     &lt;/EfilingActivityErrorXML&gt;   &lt;/EfilingActivityXML&gt;   &lt;EfilingActivityXML SeqNum="2"&gt;     &lt;BSAID&gt;31000055053785&lt;/BSAID&gt;     &lt;EfilingActivityErrorXML SeqNum="1"/&gt;   &lt;/EfilingActivityXML&gt;   &lt;EfilingActivityXML SeqNum="3"&gt;     &lt;BSAID&gt;31000055053786&lt;/BSAID&gt;     &lt;EfilingActivityErrorXML SeqNum="1"/&gt;   &lt;/EfilingActivityXML&gt; &lt;/EfilingSubmissionXML&gt; </pre>

	</EFileBatchXML>
Notes:	<p>The sample above consists of three (3) FinCEN Form 8300 activities based on the original FinCEN Form 8300 batch submission:</p> <ul style="list-style-type: none"><li>• Each FinCEN Form 8300 from the original batch submission is associated with a &lt;EFileActivityXML&gt; element</li><li>• Each FinCEN Form 8300 receives a unique BSA Identifier (BSA ID)</li><li>• FinCEN Form 8300 (BSA ID: 31000055053784) contains two errors (P05 &amp; P03)</li><li>• FinCEN Form 8300 (BSA ID: 31000055053785) contains no errors</li><li>• FinCEN Form 8300 (BSA ID: 31000055053786) contains no errors</li></ul>

## 7. Attachment A – Error Descriptions

The following table lists the errors that your batch may receive as a result of missing or invalid data formatting. FinCEN strongly encourages that filers first test their XML batch files for schema compliance using the schemas available at [www.fincen.gov/base](http://www.fincen.gov/base). Your batch file should pass schema validation before you attempt to submit to FinCEN. As a result, this table does not include all possible schema validation errors, as these will be handled by your XML software during testing. Your batch file must pass schema validation before attempting to submit to FinCEN via BSA E-Filing; otherwise, it will be rejected.

### Error Level

#### Fatal

Batch rejection

*These errors are related to the batch format and must be resolved before attempting to resubmit the batch.*

#### Primary Warning

Batch acceptance with warning(s) classified as primary data errors

*These errors violate electronic filing requirements or report instructions and so degrade FinCEN Form 8300 data quality that they must be corrected (along with warning errors) as a correction/amendment FinCEN Form 8300. Error codes marked with an asterisk (\*) in the tables below are primary warnings.*

#### Warning

Batch acceptance with warning(s) classified as secondary data errors.

*These errors that violate electronic filing requirements or report instructions but have a lesser impact on FinCEN Form 8300 data quality.*

### 7.1. General errors

These errors can occur throughout the batch file:

Code	Error Text	Severity	Associated Element(s)	Form Reference
A00	Schema Validation Failure. The batch XML does not conform to the basic schema requirements for this form type and therefore the batch submission has been rejected. Please validate the batch against the associated XML schema to ensure it is properly formatted before attempting to resubmit.	Fatal	NA	NA
A03	The element is recorded for an inappropriate party type	Fatal	Miscellaneous	Miscellaneous
A04	The element is recorded but all sub-elements are missing.	Fatal	PartyName, Address, and/or CurrencyTransactionActivity Detail	Miscellaneous
A05	The element contains a value that is not valid for the associated party type.	Fatal	PartyNameTypeCode and/or PartyIdentificationTypeCode	Miscellaneous
A06	The reported attribute count does not match the actual count.	Fatal	EFilingBatchXML: ActivityCount, TotalAmount, and/or PartyCount	NA
A07	The value is null or not equal to 8300X.	Fatal	FormTypeCode	NA
A08	The value recorded is a numeric entry less than 14 digits (with the exceptions of "0").	Fatal	EFilingPriorDocumentNumber	BSA ID

Code	Error Text	Severity	Associated Element(s)	Form Reference
A10	The value is equal to "O" (Organization) and the Person on whose behalf transaction conducted legal name is not provided.	Fatal	PartyTypeCode, RawEntityIndividualLastNam e	Part II: Item 16
A11	A DBA name is recorded for a party type not associated with the Person on whose behalf transaction conducted.	Fatal	PartyName	Part II: Item 20
A12	The PartyNameTypeCode element is not recorded for the appropriate party type.	Fatal	Party: Transmitter (35), Transmitter Contact (37), Person on whose behalf transaction conducted (23)	Part II: Items 16-18, 20
A13	The country element is recorded for the Business that received cash.	Fatal	RawCountryCodeText	Part IV
A14	At least one occurrence of the InstrumentProductServiceTypeCode element specifying the type of cash received must be recorded.	Fatal	InstrumentProductServiceTy peCode	Part III: Item 32(a-f)
A15	At least one occurrence of the CurrencyTransactionActivityDetailTypeCode element specifying the type of transaction must be recorded.	Fatal	CurrencyTransactionActivity Detail	Part III: Item 33
A16	The element is not recorded or does not contain a value and the InstrumentProductServiceTypeCode element is recorded for the parent element.	Fatal	DetailTransactionAmountTex t	Part III: Item 32(a-f)
A17	The element is recorded but does not contain a value.	Fatal	ActivityNarrativeText	Comments
A18	The value recorded is not a valid country code.	Warning	RawCountryCodeText	Miscellaneous
A19	State code and country code mismatch when country is US, CA, MX, or U.S. Territory.	Warning	RawCountryCodeText / RawStateCodeText	Miscellaneous
A20	The value recorded is not a valid state code.	Warning	RawStateCodeText	Miscellaneous
A21	The element contains a value and the country is not US, CA, MX, or a U.S. Territory.	Warning	RawStateCodeText	Miscellaneous
A22	The value recorded contains one or more non-numeric characters or is in an invalid format and the country is US or a U.S. Territory code.	Warning	RawZIPCode	Miscellaneous
A23	The critical element is not recorded or does not contain a value.	Fatal	Miscellaneous	Miscellaneous
A24	The element is not recorded or does not contain a value.	Warning	Miscellaneous	Miscellaneous
A25	The value recorded for the critical element is not valid.	Fatal	Miscellaneous	Miscellaneous
A26	The value recorded for the element is invalid.	Warning	Miscellaneous	Miscellaneous
A27	The element recorded conflicts with one or more recorded critical elements.	Fatal	Miscellaneous	Miscellaneous
A28	The element recorded conflicts with one or more recorded elements.	Warning	Miscellaneous	Miscellaneous
F60	The namespace prefix for the element is invalid.	Fatal	Miscellaneous	Miscellaneous

Code	Error Text	Severity	Associated Element(s)	Form Reference
E00	This submission has been rejected because it contains significant errors. Please fix and re-submit the file.	Information	This error code is produced when the batch is rejected due to one or more fatal errors.	Miscellaneous

## 7.2. Document Errors

These errors can occur at the FinCEN Form 8300 document level:

Code	Error Text	Severity	Associated Element(s)	Form Reference
D01	The element is not recorded and CorrectsAmendsPriorReportIndicator contains a Y value.	Warning	EfilingPriorDocumentNumber	BSA ID
D02	The element is recorded with a valid value and InitialReportIndicator contains a Y value.	Warning	EfilingPriorDocumentNumber	BSA ID
D03	The value recorded is a date greater than the current date or less than January 1, 2000.	Warning	FilingDateText	Part IV: Item 43
D04	The element is recorded with a Y value but there is only one party recorded associated with the individual from whom cash was received.	Warning	MultipleSubjectsIndicator	Part I: Item 2
D05	The MultipleSubjectsIndicator element is not recorded with a Y value and there is more than one party recorded associated with the individual from whom cash was received.	Warning	MultipleSubjectsIndicator	Part I: Item 2
D06	The element is recorded with a Y value but only one (or no) party associated with the person on whose behalf this transaction was conducted is recorded.	Warning	TransactionOnBehalfMultiplePersonsIndicator	Part I: Item 15
D07	The element is not recorded with a Y value and there is more than one party associated with the person on whose behalf this transaction was conducted recorded.	Warning	TransactionOnBehalfMultiplePersonsIndicator	Part I: Item 15
D08	Both of the following sub-elements are recorded with a null value: <CorrectsAmendsPriorReportIndicator> <InitialReportIndicator>	Warning	ActivityAssociation	Form
D09	Both of the following sub-elements are recorded with a Y value: <CorrectsAmendsPriorReportIndicator> <InitialReportIndicator>	Warning	ActivityAssociation	Form
D10	The value recorded contains leading zeros, non-numeric characters, or is equal to "0".	Warning	TotalCashInReceiveAmountText, DetailTransactionAmountText, and/or Total100DollarBillInAmountText,	Part III: Items 29, 32(a-f), 32(\$100 bills)
D11*	The element is recorded but the value is null.	Warning (Primary)	TotalCashInReceiveAmountText	Part III: Item 29
D12	The value recorded contains leading zeros, non-numeric characters, or is	Warning	TotalPriceAmountText	Part III: Item 31

Code	Error Text	Severity	Associated Element(s)	Form Reference
	equal to the TotalCashInReceiveAmountText.			
D13	The value recorded is greater than the date of signature (FilingDateText).	Warning	TransactionDateText	Part III: Item 28
D14	The element exceeds the maximum occurrence threshold (3) for the Activity.	Warning	CurrencyTransactionActivityDetailTypeCode	Part III: Item 33
D15	The element is not recorded or does not contain a value and the type of transaction is associated with "Other".	Warning	DetailTransactionDescription	Part III: Item 34
D16	The element is not recorded but the DetailTransactionAmountText element is recorded for the parent element.	Warning	InstrumentProductServiceTypeCode	Part III: Item 32
D17	The element is recorded with a value and Type of cash received is not associated with Cashier's check(s), Money order(s), Bank draft(s), or Traveler's check(s).	Warning	IssuerNameText	Part III: Item 32
D18	The element is not recorded (or does not contain a value) and Type of cash received is associated with Foreign currency.	Warning	OtherForeignCurrencyCountryText	Part III: Item 32
D19	The element is recorded with a valid country code and Type of cash received is NOT associated with Foreign currency.	Warning	OtherForeignCurrencyCountryText	Part III: Item 32
D20	The value recorded is not a valid country code.	Warning	OtherForeignCurrencyCountryText	Part III: Item 32
D21	The value recorded is equal to US or a US Territory.	Warning	OtherForeignCurrencyCountryText	Part III: Item 32
D22	Missing Transmitter party type	Fatal	Transmitter (35)	NA
D23	More than one Transmitter party type is recorded.	Fatal	Transmitter (35))	NA
D24	Missing Transmitter Contact party type.	Fatal	Transmitter Contact (37)	NA
D25	More than one Transmitter Contact party type recorded.	Fatal	Transmitter Contact (37)	NA
D26	Missing party type for the Individual from whom the cash was received.	Fatal	Individual from whom the cash was received (16)	Part I: Items 3-14
D27	More than 99 party types are recorded for the Individual from whom the cash was received.	Fatal	Individual from whom the cash was received (16)	Part I: Items 3-14
D28	More than 99 party types are recorded for the Person on whose behalf transaction conducted.	Fatal	Person on whose behalf transaction conducted (23)	Part II: Items 16-27
D29	Missing party type for Business that received cash.	Fatal	Business that received cash (4)	Part IV: Items 35-41
D30	More than one party type is recorded for the Business that received cash.	Fatal	Business that received cash (4)	Part IV: Items 35-41
D31	More than one party type is recorded for the Authorized Official.	Fatal	Authorized Official (3)	Part IV: Item 42
D32	More than one party type is recorded for the Contact for assistance.	Fatal	Contact for assistance (8)	Part IV: Items 44-45

### 7.3. Individual from whom cash was received (Part I) & Person on whose behalf this transaction was conducted (Part II) Errors

These errors can occur at the FinCEN Form 8300 document level associated with the Part I Individual from whom cash was received and also the Part II Person on whose behalf this transaction was conducted sections of the form:

Code	Error Text	Severity	Associated Element(s)	Form Reference
P01	The date of birth recorded is prior to January 1, 1900.	Warning	IndividualBirthDateText	Part I: Item 8
P02	The date of birth recorded is greater than the date cash was received (TransactionDateText).	Warning	IndividualBirthDateText	Part I: Item 8
P03*	The legal name is not recorded.	Warning (Primary)	PartyName/RawEntityIndividualLastName	Part I: Items 3 (or 3-5 are all missing)
P05	The element is not recorded or does not contain a value and the PartyIdentificationTypeCode is equal to 5 (Driver's License/State ID), 6 (Passport), or 7 (Alien registration).	Warning	OtherIssuerStateText	Part I: Item 14b / Part II: Item 27b
P06	The element is recorded or contains a value and the PartyIdentificationTypeCode is NOT equal to 5 (Driver's License/State ID), 6 (Passport), 7 (Alien registration), or 999 (Other).	Warning	OtherIssuerStateText	Part I: Item 14b / Part II: Item 27b
P07	The element contains a value that is not a valid state/country/U.S. Territory code.	Warning	OtherIssuerStateText	Part I: Item 14b / Part II: Item 27b
P10*	The value recorded is an invalid number string for SSN/ITIN.	Warning (Primary)	PartyIdentificationNumberText	Part I: Item 6
P11	The value recorded is an invalid number string for SSN/ITIN and/or EIN.	Warning	PartyIdentificationNumberText	Part II: Item 19

### 7.4. Business that received cash (Part IV) & Comments Errors

These errors can occur at the FinCEN Form 8300 document level associated with the Part IV Business that received cash, as well as the Comments, sections of the form:

Code	Error Text	Severity	Associated Element(s)	Form Reference
B01*	The legal name is not recorded.	Warning (Primary)	Business that received cash	Part IV: Item 35
B02*	The element is not recorded or does not contain a value for the Business that received cash.	Warning (Primary)	RawPartyFullName	Part IV: Item 35
B03	The element is recorded but does not contain a value	Warning	Contact for assistance: PhoneNumberText	Part IV: Item 45
B04	The value recorded does not equal 10 numeric characters.	Warning	PhoneNumberText	Part IV: Item 45
B05*	The element is not recorded for this party type information.	Warning (Primary)	PartyIdentification	Part IV: Item 36 (EIN, SSN)
B06*	The value recorded is an invalid number string for EIN or SSN.	Warning (Primary)	PartyIdentificationNumberText	Part IV: Item 36 (EIN, SSN)

### 7.5. Transmitter & Transmitter Contact Errors

These errors can occur at the FinCEN Form 8300 document level associated with Transmitter of the batch as well as the Transmitter Contact:



Code	Error Text	Severity	Associated Element(s)	Form Reference
T01	The legal name is not recorded.	Warning	Party: Transmitter (35) and/or Transmitter contact (37)	NA
T02	The element is not recorded.	Warning	Address (Transmitter (35))	NA
T03	The element is not recorded or does not contain a value.	Warning	RawCityText (Transmitter (35))	NA
T04	The element is not recorded or does not contain a value.	Warning	RawCountryCodeText (Transmitter (35))	NA
T05	The element is not recorded or does not contain a value when the country is US, CA, MX, or a U.S. Territory.	Warning	RawStateCodeText (Transmitter (35))	NA
T06	The element is not recorded or does not contain a value.	Warning	RawStreetAddress1Text (Transmitter (35))	NA
T07	The element is not recorded or does not contain a value.	Warning	RawZIPCode (Transmitter (35))	NA
T08	The element is recorded but does not contain a value	Warning	PhoneNumberText (Transmitter (35))	NA
T09	The element is not recorded for this party type information.	Warning	PartyIdentification (TIN) (Transmitter (35))	NA
T10	The element is not recorded for this party type information.	Warning	PartyIdentification (TCC) (Transmitter (35))	NA

## 8. Attachment B – Error Correction Instructions

This attachment identifies the requirements and procedures for correcting FinCEN Form 8300 errors reported to batch filers during the FinCEN Form 8300 acknowledgement process.

### Error Categories:

There are two main categories of errors identified in batch files: Schema validation errors that result in automatic rejection of the batch file and data errors that represent errors in data entered for individual elements but may not result in a rejection.

Schema validation errors prevent the batch file from being processed and are considered fatal errors. An example of a schema validation error is a missing required element or an element sequence that does not match the schema. An example of a data error is a required element that contains no value.

Data errors are classified as primary or secondary warnings, depending on their importance. Primary warnings are file errors that violate electronic filing requirements or instructions and so degrade FinCEN Form 8300 data quality that they must be corrected. Primary warnings make it difficult for regulators, analysts, and law enforcement investigators to locate the FinCEN Form 8300 in the database or identify the nature and circumstances of the FinCEN Form 8300. Examples of such warnings include blank last names or legal names, missing financial institution Employer Identification Numbers, or an invalid entry in the FinCEN Form 8300 date field. Attachment A – Error Descriptions identifies primary errors by adding an asterisk (\*) to the error code.

Secondary warnings are data errors that violate electronic filing requirements or instructions but have a lesser impact on FinCEN Form 8300 data quality. Examples of secondary errors are ZIP Codes that end in four zeros (e.g. 123450000), missing dates of birth, or invalid telephone numbers.

### Correction Requirements:

Filers should immediately correct and resubmit a batch file rejected for fatal errors when notified by FinCEN the batch file was not accepted.

When an accepted batch file contains FinCEN Form 8300 with primary warning errors, those FinCEN Form 8300 must be re-filed as a corrected report with the primary errors and any secondary errors corrected. FinCEN Form 8300 that contain only secondary errors need not be corrected. FinCEN requires that filers prevent all reported errors in their future filings. FinCEN recommends that data error corrections be made no later than 30 days after receiving error notifications. Furthermore, FinCEN recommends that filers remedy any systemic problems in their electronic submissions within 30 days of receiving error notifications. If technical issues prevent filers from implementing corrections within these time frames, filers should notify FinCEN by writing to:

Financial Crimes Enforcement Network  
Office of Domestic Liaison  
Data Quality Assessments  
P.O. Box 39  
Vienna, VA 22183

This correspondence should explain the technical issues involved that prevent meeting the time frame, provide an estimate of when the issues will be resolved, and include a contact name and telephone number.

### Correction Procedures:

FinCEN Form 8300 batch files are rejected when they contain fatal format errors. Filers must correct all fatal errors identified in the batch file and resubmit the batch file to BSA E-Filing. Because they were not accepted by FinCEN, initial report FinCEN Form 8300 in the re-submitted batch file are still initial reports. Do not identify FinCEN Form 8300 from a rejected batch file as Amended reports unless they originally were filed as Amended reports.

If errors in a FinCEN Form 8300 from an accepted batch file involve primary warning errors, filers should correct all errors (primary and secondary warning errors) and file an amended report on that FinCEN Form 8300 using the following procedures:

- Make the corrections to all errors in the FinCEN Form 8300 in the accepted batch file.

- Record "Y" in the <CorrectsAmendsPriorReportIndicator> element under the <Activity Association> element in each FinCEN Form 8300 to be corrected.
- Record in the <EFilingPriorDocumentNumber> element under the <Activity> element the BSA Identifier (from the FinCEN Form 8300 Acknowledgement) that was assigned to the FinCEN Form 8300 being corrected.
- Ensure that the <FilingDateText> element contains a new date.
- Complete all other data in the FinCEN Form 8300 in their entirety.
- Transmit the corrected FinCEN Form 8300 in a new batch file. Do not re-transmit the original batch file because this will cause duplicate database entries on FinCEN Form 8300s that were not corrected.

## 9. Attachment C – Electronic XML Filing Instructions

The following instructions apply only to the electronic filing of the Report of Cash Payments Over \$10,000 Received in Trade or Business, FinCEN Form 8300, through FinCEN's BSA E-Filing System. Unless specifically mentioned in the text, these instructions do not apply to any other current or prior Bank Secrecy Act reports.

### General Instructions

1. **Who must file.** Any person in a trade or business who, in the course of that trade or business, receives more than \$10,000 in cash in a single transaction or in two or more related transactions, must file FinCEN Form 8300. Any transactions conducted between a payer or the payer's agent and the recipient in a 24-hour period are related transactions. Transactions are considered related even if they occur over a period of more than 24 hours if the recipient knows, or has reason to know, that each transaction is one of a series of connected transactions.
3. **Where to file.** The batch-filed or discrete electronic FinCEN Form 8300 must be filed through the Financial Crimes Enforcement Network (FinCEN) BSA E-Filing System. To obtain an application to E-file, go to <http://bsaefiling.fincen.treas.gov/main.html>. For help in applying, contact the E-Filing Help Desk by calling 1-866-346-9478 (option 2) or via e-mail sent to [BSAEFilingHelp@fincen.gov](mailto:BSAEFilingHelp@fincen.gov).
4. **When to file.** FinCEN Form 8300 must be filed by the 15<sup>th</sup> day after the date the cash was received. If the 15<sup>th</sup> day falls on a Saturday, Sunday, or legal holiday, the FinCEN Form 8300 can be filed on the next business day.
5. **Voluntary filing.** FinCEN Form 8300 may be filed voluntarily for any suspicious transaction for use by FinCEN and the Internal Revenue Service (IRS), even if the total amount does not exceed \$10,000. Voluntary filers are encouraged report the suspicious transaction directly to the local IRS Criminal Investigation Division, and to the FinCEN Financial Institution Hotline toll free at 1-866-556-3974.
6. **Retention requirements.** A copy of each FinCEN Form 8300 must be retained for five years from the date it was filed.
7. **Exceptions.** Cash is not required to be reported if it is received:
  - By a financial institution required to file the FinCEN Currency Transaction Report (CTR), Form 112.
  - By a casino required to file a CTR if the cash is received as part of gaming activities. Cash in excess of \$10,000 received for non-gaming activities by a casino must be reported on FinCEN Form 8300.
  - By an agent who receives the cash from a principal, if the agent uses all of the cash within 15 days in a second transaction that is reportable on FinCEN Form 8300 or on a CTR, and discloses all the information necessary to complete Part II of FinCEN Form 8300 or a CTR by the recipient of the cash in the second transaction.
  - In a transaction occurring entirely outside the United States. See IRS Publication 1544, Reporting Cash Payments of Over \$10,000 (Received in a Trade or Business) (Publication 1544), regarding transactions occurring in Puerto Rico and territories and possessions of the United States.
  - In a transaction that is not in the course of a person's trade or business.
8. **Statement to be provided.** The filer of a FinCEN Form 8300 must give a written or electronic statement to each person named on a required FinCEN Form 8300 on or before January 31 of the year following the calendar year in which the cash was received. The statement must show the name, telephone number, and address of the information contact for the business; the aggregate amount of reportable cash received; and a notice that the information was furnished to the Internal Revenue Service (IRS). A copy of this statement must be kept in the filer's records.
9. **Penalties.** You may be subject to penalties if you fail to file a correct and complete FinCEN Form 8300 on time and you cannot show that the failure was due to reasonable cause. You may also be subject to penalties if you

fail to furnish timely a correct and complete statement to each person named in a required report. A minimum penalty of \$25,000 may be imposed if the failure is due to an intentional or willful disregard of the cash reporting requirements. Penalties may also be imposed for causing, or attempting to cause, a trade or business to fail to file a required report; for causing, or attempting to cause, a trade or business to file a required report containing a material omission or misstatement of fact; or for structuring, or attempting to structure, transactions to avoid the reporting requirements. These violations may also be subject to criminal prosecution which may result in imprisonment of up to 5 years or fines of up to \$250,000 for individuals and \$500,000 for corporations or both.

**10. Definitions.** For purposes of FinCEN Form 8300, the terms below have the following meanings:

- **Cash.** The term “cash” means the following.
  - U.S. and foreign coin and currency received in any transaction; or
  - A cashier’s check, money order, bank draft, or traveler’s check having a face amount of \$10,000 or less that is received in a designated reporting transaction (defined below), or that is received in any transaction in which the recipient knows that the instrument is being used in an attempt to avoid the reporting of the transaction under either section 6050I or 31 U.S.C. 5331.

**Note:** Cash does not include a check drawn on the payer’s own account, such as a personal check, regardless of the amount. In text the meaning of the word “Currency” for purposes of 31 U.S.C.5331 is the same as for the word “cash.”

- **Collectible.** Any work of art, rug, antique, metal, gem, stamp, coin, etc.
- **Consumer durable.** An item of tangible personal property of a type that, under ordinary usage, can reasonably be expected to remain useful for at least 1 year, and that has a sales price of more than \$10,000.
- **Designated reporting transaction.** A retail sale (or the receipt of funds by a broker or other intermediary in connection with a retail sale) of a consumer durable, a collectible, or a travel or entertainment activity.
 

**Note:** A cashier’s check, money order, bank draft, or traveler’s check is not considered received in a designated reporting transaction if it constitutes the proceeds of a bank loan or if it is received as a payment on certain promissory notes, installment sales contracts, or down payment plans. See IRS Publication 1544 for more information.
- **Person.** An individual, corporation, partnership, trust, estate, association, or company.
- **Recipient.** The person receiving the cash. Each branch or other unit of a person’s trade or business is considered a separate recipient unless the branch receiving the cash (or a central office linking the branches), knows or has reason to know the identity of payers making cash payments to other branches.
- **Related Transaction.** Any transaction between a buyer or buyer’s agent and a seller that occurs within a 24-hour period. Transactions are related even if they are more than 24 hours apart and the seller knows or has reason to know the transactions are part of a series of connected transactions.
- **Retail sale.** Any sale (whether or not the sale is for resale or for any other purpose) made in the course of a trade or business if that trade or business principally consists of making sales to ultimate consumers.
- **Suspicious transaction.** A suspicious transaction is a transaction in which it appears that a person is attempting to cause FinCEN Form 8300 not to be filed, is attempting to cause a false or incomplete FinCEN Form 8300 to be filed, or is involved in possible illegal activity.
- **Transaction.** Includes the purchase of property or services, the payment of debt, the exchange of cash for a negotiable instrument, and the receipt of cash to be held in escrow or trust. A single transaction may not be broken into multiple transactions to avoid reporting.
- **Travel or entertainment activity.** An item of travel or entertainment that pertains to a single trip or event if the combined sales price of the item and all other items relating to the same trip or event that are sold in the same transaction (or related transactions) exceeds \$10,000.

**11. Exceptions to definition of cash.** A cashier’s check, bank draft, traveler’s check, or money order (collectively “monetary instruments”) received in a designated reporting transaction is not treated as cash if one of the following exceptions applies.

- The monetary instruments are the proceeds from a bank loan. A recipient may rely on a copy of the loan document, a written statement, or lien instructions from the bank as proof of the loan.
- The monetary instruments are received in payment on a promissory note or installment sales contract, including a least that is considered a sale for federal tax purposes. The recipient must use similar notes or contracts in the ordinary course of its trade or business, and the total of payments in the 60 days following the sale are 50% or less than the purchase price.
- The monetary instruments are received in payment for a consumer durable or collectible. The payment plan must require one or more down payments and payment of the purchase price by the date of the sale. The monetary instruments are received more than 60 days before the sale date. The recipient uses similar terms when selling to ultimate consumers in the ordinary course of trade or business.
- The monetary instruments are received in payment for travel or entertainment. The payment plan must require one or more down payments and payment of the purchase price by the date of the sale. The monetary instruments are received more than 60 days before the sale date. The recipient uses similar terms when selling to ultimate consumers in the ordinary course of trade or business.

**12. Recording information.** Complete each FinCEN Form 8300 by providing as much information as possible. All items should be completed fully and accurately when the data are known to the filer. If an item's instructions differ from this general instruction, the item instructions must be followed.

**Note:** Throughout these instructions the phrases "check box," "select option," and similar wording are used to denote actions in certain data items on the discrete FinCEN Form 8300. These are deemed equivalent to instructions in the FinCEN Form 8300 XML User Guide to enter appropriate codes in the associated data elements batch files.

**13. Amended reports.** An amended FinCEN Form 8300 must be filed whenever additional data about the transactions are discovered or corrections to previously submitted data must be made. Amended reports must be completed in their entirety, with the necessary corrections or amendments made to the data. Box 1a Amends prior report" must be checked. On the discrete FinCEN Form 8300 header page Submission Type will be "Amendment" and the BSA Identifier (BSA ID) field must contain the BSA ID of the FinCEN Form 8300 being corrected. Box 1a is checked by selecting "Amendment" in Submission Type. If the BSA ID is unknown, enter all zeros in this field. BSA IDs are provided in acknowledgement records/messages sent to FinCEN Form 8300 filers by the BSA E-Filing System.

**14. Addresses.** For addresses in the U.S., Canada, or Mexico enter the permanent street address, city, two or three letter state/territory/province abbreviation or code, ZIP Code or foreign postal code, and two-letter country or U.S. Territory code. Provide the apartment number or suite number, if known, following the street address. A non-location address such as a post office box or rural route number should be used only if no other street address information is available. ZIP Codes must be five or nine digits, entered without formatting or special characters such as spaces or hyphens. For example, the ZIP Code 12345-6120 would be entered as 123456120. Foreign postal codes may be alpha/numeric and should be entered without formatting or special characters. Foreign postal code HKW 358 would be entered as HKW358. When an address is in a U.S. Territory the territory code must be entered in the state and country fields. For foreign addresses other than Canada or Mexico enter the street address, city, postal code, and two letter country code or address equivalents. Leave the state item blank. If a foreign address contains address information that does not conform to the FinCEN Form 8300 address format, record equivalent address information in the address items and ignore non-conforming data. Complete any address item that is known, even if the entire address is not known. Abbreviations in city names are permitted only if the full name is too long for that field. U.S. city names must match the city names used by the U.S. Postal Service for the associated state and ZIP Code. U.S. State and Territory codes must conform to the codes used by the United States Postal Service as documented in ISO 3166-2:US. Canadian province and territory codes must conform to ISO 3166-2:CA. The state codes for Mexico must conform to ISO 3166-2:MX. Country codes and U.S. Territory Codes must conform to the codes documented in ISO 3166-2. The ISO lists are available through the International Standards Organization. NOTE: The ISO 3166-2 country list contains the code "UM" that stands for the United State Minor Outlying Islands. Using "UM" in country fields is prohibited. These islands are

uninhabited. As such they have no addresses.

- 15. Telephone numbers.** Record telephone numbers as a single number string without formatting or special characters such as parentheses, spaces, or hyphens. For example, a number in the format (NNN) NNN-NNNN would be recorded as NNNNNNNNNN.
- 16. Identifying numbers.** Enter all identifying numbers as a single alpha/numeric text string without formatting such as spaces or special characters such as hyphens or periods. An identifying number in the format NNN-NN-NNNN would be entered as NNNNNNNNNN. Such numbers may include letter and number characters. Common identifying numbers include serial numbers, alien registration numbers, driver's license and state identification numbers, Employer Identification Numbers (EIN), passport numbers, and Social Security Numbers (SSN). Do not include characters that are not part of the actual identifying number. Special characters and formatting such as spaces, leading zeros, prefixes, and suffixes in identifying numbers are prohibited.
- 17. Monetary amounts.** Record all amounts as U.S. Dollar amounts rounded up to the next whole dollar. The amount \$15,265.25 would be recorded as \$15,266. When converting a foreign currency to dollars use an exchange rate available to the public for the date of the transaction. Never report a foreign currency amount in FinCEN Form 8300. Always report the U.S. Dollar equivalent.
- 18. Determining whether transactions meet the reporting threshold.** Cash transactions as defined in Attachment C General Instruction 10 "Definitions" that, if alone or when aggregated, exceed \$10,000 and are received in trade or business must be reported on the FinCEN Form 8300. Cash in the form of cashier's check, money order, bank draft, or traveler's check must have a face amount of \$10,000 or less. U.S. and foreign currency amounts greater than \$10,000 must be reported. For example, a transaction involving payment through money orders of \$5,000 and \$6,000 for a total of \$11,000 must be reported because each is under the reporting requirement. A transaction involving payment via a single cashier's check for \$11,000 would not be reported because the instrument is greater than \$10,000. A transaction or related transactions paid for by a mixture of cash types that exceed \$10,000 must be reported, e.g. a transaction paid for with a \$6,000 money order and \$5,000 in U.S. Currency. A FinCEN Form 8300 can be voluntary filed on an amount or aggregated amount below the reporting threshold in cases where the transaction activity is deemed suspicious by the filer and Box 1b "Suspicious transaction" is checked. See IRS Publication 1544 for additional information on identifying reportable cash transactions.
- 19. Prohibited words and phrases.** Do not use the following words or variations of these words in fields:
- AKA
  - COMPUTER GENERATED
  - CUSTOMER
  - DBA
  - NONE
  - NOT APPLICABLE
  - NON CUSTOMER
  - OTHER
  - SAME
  - SAME AS ABOVE
  - SEE ABOVE
  - SIGNATURE CARD
  - UNKNOWN
  - VARIOUS
  - XX
- 16. Name Editing Instructions.** Because many names do not consist of a single first name, middle name, and last name, care must be taken to ensure these names are entered properly in the FinCEN CTR. This is especially important when there are separate fields for the last name, first name, and middle name. Some names have

multiple surnames (family names) or multiple given names that do not include a middle name. Others may not be written in [first name] [middle name] [last name] order. Multiple surnames must be entered in the last name field. For example, Hispanic names may be written in the order of given name, father's last name, and mother's last name, e.g., "Juan Vega Santiago." Thus the surname "VEGA SANTIAGO" would be entered in the last name field with "JUAN" entered in the first name field. Some Hispanic surnames consist of three names (e.g., father's last name, mother's last name, and husband's father's last name in the case of a married woman). In that case all three would be entered in a last name field. Hispanic names do not have middle names, so a multiple Hispanic given name such as "Rosa Maria" would be recorded in the first name field. In some cultures names consist of multiple first names and a single family name, not necessarily in (first name) (last name) order. For example, the Korean name "Kim, Chun Nam" consists of the family name "Kim" and the first name "Chun Nam" separated by a comma and space. There is no middle name. In this case "KIM" would be entered in the last name field and "CHUN NAM" would be entered in the first name field. Nothing is entered in the middle name field. When an individual name is entered in a single name field it should be entered in [first name] [middle name] [last name] order regardless of any foreign naming conventions. Thus, "Kim, Chun Nam" would be entered as "CHUN NAM KIM" in a single name field. Punctuation and special characters should be used in names only when they are part of the name. For example, the period in "Expedia.Com" should be included because it is part of the name. Placing a period after a middle initial would be prohibited because the period is not part of the middle name. Abbreviations in names are prohibited unless an abbreviation is part of a legal name. Entry of middle initials is permitted when a middle name is unknown. A name suffix may be abbreviated, i.e. Junior can be JR, Senior can be SR, the Third can be III, etc.

## 17. Additional Guidance:

For additional guidance regarding FinCEN Form 8300 filing requirements or for more detailed instructions, please go to [www.irs.gov](http://www.irs.gov) and search for FinCEN Form 8300. Following are some helpful IRS links:

- IRS Publication 1544: <https://www.irs.gov/pub/irs-pdf/p1544.pdf>
- General Guidance: <https://www.irs.gov/businesses/small-businesses-self-employed/form-8300-and-reporting-cash-payments-of-over-10000>
- Paper Filed Form/Instructions: <https://www.irs.gov/pub/irs-pdf/f8300.pdf>
- Reference Guide: <https://www.irs.gov/businesses/small-businesses-self-employed/irs-form-8300-reference-guide>
- Dealership FAQs: <https://www.irs.gov/businesses/small-businesses-self-employed/report-of-cash-payments-over-10000-received-in-a-trade-or-business-motor-vehicle-dealership-qas>

## Item Instructions

### Header Page

Header Page: On the discrete FinCEN Form 8300 header page enter a descriptive name in the Filing Name Field to identify the filing. In Submission Type select "New" if the FinCEN Form 8300 is an initial filing, i.e. the first filing on a reportable transaction or related transactions that exceed \$10,000. Select "Amendment" if the FinCEN Form 8300 amends a prior filing or is a second filing when related transactions exceed another \$10,000 following the initial FinCEN Form 8300's filing. When "Amendment" is selected enter in the BSA Identifier (BSA ID) field the prior FinCEN Form 8300's BSA ID. If the BSA ID is unknown enter 14 zeros (00000000000000) in this field.

### 1. Check appropriate box(s) if:

- a. Amends prior report
- b. Suspicious transactions



Item 1 Check appropriate boxes(s): box 1a "Amends prior report" is automatically checked when "Amendment" is selected in Submission Type on the discrete FinCEN Form 8300 header page. If the transaction(s) reported in the FinCEN Form 8300 are suspicious, check box 1b "Suspicious transactions." Describe in the Comments section what was suspicious about the transactions. See General Instruction 10 "Definitions" for information on what constitutes a suspicious transaction.

## **Part I Identity of Individual From Whom the Cash Was Received.**

### **2. If more than one individual is involved, check here**

Item 2 Check if more than one individual is involved: If the transactions were conducted by multiple individuals, check box 2 and prepare a Part I section on each individual involved.

### **3. Last name**

Item 3 Last name: Enter the last name of the individual that conducted the transaction(s). See General Instruction 16 for information on entering the names of individuals.

### **4. First name**

Item 4 First name: Enter the first name of the individual that conducted the transaction(s).

### **5. M.I.**

Item 5 M.I. (middle initial): Enter the middle initial, if known, of the individual that conducted the transaction(s).

### **6. Taxpayer identification number**

Item 6 Taxpayer identification number (TIN): Enter the TIN of the individual that conducted the transactions(s) if known. If the TIN is unknown, Item 14 "Identifying document (ID) must be completed.

### **7. Address (number, street, and apt. or suite no.)**

Item 7. Address: Enter the street address of the individual that conducted the transaction(s). Include any suite or apartment number that is part of the address. See General Instruction 11 for additional information on entering address data, including city, state, ZIP Code, and country.

### **8. Date of birth**

Item 8 Date of birth: Enter the date of birth of the individual that conducted the transaction(s) in MM/DD/YYYY format where MM = month, DD = day, and YYYY = year. Precede any single month or day with a zero. March 9, 1979 would be entered 03/09/1979.

### **9. City**

Item 9 City: Enter the city of the individual that conducted the transaction(s). All city names must be spelled out. Abbreviations are only permitted when a city name is too long for the Item 9 field.

### **10. State**

Item 10 State: Select from the dropdown list the appropriate province/state/territory code for the individual that conducted the transaction(s) if the individual's country is Canada, Mexico, or the U.S. Leave Item 10 blank if the address is in any other country. When the address is in Canada, Mexico, or the U.S. select the appropriate country

code from Item 12 "Country" dropdown list first and then select the state field entry from the dropdown list associated with the country entry.

### **11. ZIP Code**

Item 11 ZIP Code: Enter the ZIP Code or foreign postal code for the individual that conducted the transaction(s). Formatting or special characters such as spaces or hyphens are prohibited in ZIP Codes and foreign postal codes.

### **12. Country**

Item 12 Country: Select from the dropdown list the country or U.S. Territory associated with the individual that conducted the transaction(s).

### **13. Occupation, profession, or business**

Item 13 Occupation, profession, or business: Describe the nature of the individual's occupation, profession, or business (for example "plumber," "attorney," or "automobile dealer"). Do not use general or non-descriptive terms such as "businessman" or "self-employed." If the individual is retired or unemployed, describe the individual's previous occupation, such as "retired attorney" or "unemployed roofer."

### **14. Identifying document (ID)**

- a. Describe ID
- b. Issued by
- c. Number

Item 14 Identifying document (ID): Verify the name and address of the named individual(s) by examination of a document normally accepted as a means of identification when cashing checks. In 14a select the ID type "Passport," "Driver's License/State ID," "Alien Registration," or Other as appropriate. In 14b select the issuer of the document from a dropdown list that contains country entries and state/province, territory entries for the U.S., Canada, and Mexico. If the ID issuer is not in the dropdown list, select instead the country, province, state, or territory where the ID was issued. In 14c enter the ID number without formatting or special characters. Although both should be completed if the FinCEN Form 8300 filer has the data, either Item 6 "Taxpayer identification number" or Item 14 must be completed.

## **Part II Person on Whose Behalf This Transaction Was Conducted**

### **15. If this transaction was conducted on behalf of more than one person, check here**

Item 15 Conducted on behalf of more than one person: If the transaction was conducted on behalf of multiple persons, check this box and prepare a Part II section on each person the transaction was conducted on behalf of.

### **16. Individual's last name or organization's name**

Item 16 Individual's last name or organization's name: Enter the last name of the individual or the full name of the organization that the transaction was conducted on behalf of.

### **17. First name**

Item 17 First name: Enter the first name of the individual the transaction was conducted on behalf of. If the person is an organization leave Item 17 blank.

**18. M.I.**

Item 18 M.I. (middle initial): Enter the middle initial, if known, of the individual the transaction was conducted on behalf of. If the person is an organization leave Item 17 blank.

**19. Taxpayer identification number**

Item 19 Taxpayer identification number (TIN): Enter the TIN of the individual the transaction was conducted on behalf of, if known. If the individual is a sole proprietor and the sole proprietorship has an EIN, that EIN must be recorded also. If the TIN and EIN is unknown, Item 27 "Alien Identification (ID)" must be completed.

**19. Employer identification number**

Item 19 Employer identification number (EIN): Enter the EIN of the organization the transaction was conducted on behalf of, if known. If the organization is a sole proprietorship with an EIN, the sole proprietor's TIN must be recorded in Item 19 also. If the TIN and EIN is unknown, Item 27 "Alien Identification (ID)" must be completed.

**20. Doing Business As (DBA) name**

Item 20 Doing Business As (DBA) name: Enter the DBA name of organization or sole proprietorship in Item 20 if the DBA name is different from the name entered in Item 16. Leave Item 20 blank if there is no DBA name.

**21. Address (number, street, and apt. or suite no.)**

Item 21 Address: Enter the street address of the person the transaction was conducted on behalf of. Include any suite or apartment number that is part of the address. See General Instruction 11 for additional information on entering address data, including city, state, ZIP Code, and country.

**22. Occupation, profession, or business**

Item 22 Occupation, profession, or business: Describe the nature of the person's occupation, profession, or business (for example "plumber," "attorney," or "automobile dealership"). Do not use general or non-descriptive terms such as "businessman," "store," or "self-employed." If the person is an individual who is retired or unemployed, describe the individual's previous occupation, such as "retired attorney" or "unemployed roofer."

**23. City**

Item 23 City: Enter the city of the person the transaction was conducted for. All city names must be spelled out. Abbreviations are only permitted when a city name is too long for the Item 23 field.

**24. State**

Item 24 State: Select from the dropdown list the appropriate province/state/territory code for the person the transaction was conducted on behalf of if the country is Canada, Mexico, or the U.S. Leave Item 10 blank if the address is in any other country. When the address is in Canada, Mexico, or the U.S. select the appropriate country code from Item 26 "Country" dropdown list first and then select the state field entry from the dropdown list associated with the country entry.

**25. ZIP Code**

Item 25 ZIP Code: Enter the ZIP Code or foreign postal code for the person the transaction was conducted on behalf of. Formatting or special characters such as spaces or hyphens are prohibited in ZIP Codes and foreign postal codes.

**26. Country**

Item 26 Country: Select from the dropdown list the country or U.S. Territory associated with the person the transaction was conducted on behalf of.

**27. Alien identification (ID)**

- a. Describe ID
- b. Issued by
- c. Number

Item 27 Alien identification (ID): Verify the name and address of the named person by examination of a document normally accepted as a means of identification when cashing checks. In 27a select the ID type "Passport," "Driver's License/State ID," "Alien Registration," or "Other" as appropriate. In 27b select the issuer of the document from a dropdown list that contains country entries and state/province, territory entries for the U.S., Canada, and Mexico. If the ID issuer is not in the dropdown list, select instead the country, province, state, or territory where the ID was issued. In 27c enter the ID number without formatting or special characters. Although all should be completed if the FinCEN Form 8300 filer has the data, either Item 19 "Taxpayer identification number," Item 19 "Employer identification number," or Item 27 must be completed.

**Part III Description of the Transaction and Method of Payment Amount and Type of Transaction(s)****28. Date cash received**

Item 28 Date cash received: Enter the date the cash was received. If the cash was received in more than one payment, enter the date you received the payment that caused the combined amount to exceed \$10,000. Enter the date in MM/DD/YYYY format where MM = month, DD = day, and YYYY = year. Any single digit month or day must be preceded by a zero.

**29. Total cash received**

Item 29 Total cash received: Enter the total cash received as of the date that cash amount exceeded \$10,000 within a 12-month period. If a previous FinCEN Form 8300 was filed on a reportable payment or related payments and additional related payments have been received, record the total amount received as of the date the total of new related payments exceeded an additional \$10,000 within a new 12-month period.

**30. If cash was received in more than one payment, check here**

Item 30 Cash received in more than one payment: Check this box if the FinCEN Form 8300 is reporting multiple related payments that exceed 10,000.

**31. Total price if different from Item 29**

Item 31 Total price if different from Item 29: Enter the total price of the property, services, amount of cash exchanged, etc. involved in the transaction if the total price is different from the amount entered in Item 29.

**32. Amount of cash received (in U.S. dollar equivalent)**

- a. U.S. currency
- b. Foreign currency
- c. Cashier's check(s)
- d. Money order(s)

- e. Bank draft(s)
- f. Traveler's check(s)

Amount in \$100 bills

Country

Issuers name(s) and serial numbers

Item 32 Amount of cash received. Enter the amount of cash received for each type of cash provided in the transaction payment. Record in "Amount in \$100 bills" the amount of U.S. Currency that was paid in \$100 bills. If payment was made in foreign currency, select the name of the country that issued the currency from the dropdown list "Country." If foreign currency from multiple countries is involved, record one country in Item 32 "Country" and record other country data in the Comments section. If the cash involved cashier's checks, money orders, bank drafts, or traveler's checks record the issuer names and serial numbers in the "Issuer's name(s)..." field. If that field is too small to record all the data, record the additional names/serial numbers in the Comments section.

### 33. Type of transaction

- a. Personal property purchased
- b. Real property purchased
- c. Personal services provided
- d. Business services provided
- e. Intangible property purchased
- f. Debt obligations paid
- g. Exchange of cash
- h. Escrow or trust funds
- i. Bail received by court clerks
- z. Other (specify in Item 34)

Item 33 Type of transaction: Check the appropriate box(es) that describe the transaction. If the transaction type is not specified in boxes 33a-l, checkbox 33j and briefly describe the transaction in Item 34 "Specific description..." If the transaction relates to the receipt of bail by a court clerk, check box 33i "Bail received by court clerks." That box is only for use by court clerks. If the transaction relates to cash received by a bail bondsman, check box 33d "Business services provided."

### 34. Specific description of property or service shown in 33.

Item 34 Specific description...: Use this field to provide descriptions of the transaction(s) reported in Item 33. These descriptions could include the addresses of real property, the VIN numbers of automobiles, serial numbers of personal property, personal or business services provided, etc.

## Part IV Business That Received Cash

### 35. Name of business that received cash

Item 35 Name of business that received cash: Enter the full name of the organization that received the cash. If the organization is a sole proprietorship operating under the proprietor's name, enter that name in First Name, Middle Initial, Last Name order.

### 36. Employer identification number

Item 36 Employer identification number (EIN): Enter the EIN of the organization that received the cash. If the organization is a sole proprietorship with an EIN, the sole proprietor's TIN must be recorded in Item 36 also.

### 36. Social security number

Item 36 Social security number (SSN): Enter the SSN of the individual when that individual is a sole proprietor. If the sole proprietorship has an EIN, that EIN must be recorded also.

### **37. Address (number, street, and apt. or suite no.)**

Item 21 Address: Enter the street address of the person that received the cash. Include any suite or apartment number that is part of the address. See General Instruction 11 for additional information on entering address data, including city, state, ZIP Code, and country.

### **38. City**

Item 23 City: Enter the city of the person that received the cash. All city names must be spelled out. Abbreviations are only permitted when a city name is too long for the Item 38 field.

### **39. State**

Item 24 State: Select from the dropdown list the appropriate U.S. state or territory of the person that received the cash.

### **40. ZIP Code**

Item 40 ZIP Code: Enter the five or nine-digit ZIP Code for the person that received the cash.

### **41. Nature of your business**

Item 41 Nature of your business: Describe the nature of the business of the person that received the cash, for example "attorney" or "Jewelry dealer." Do not use general or non-descriptive terms such as "business" or "store."

### **42. Signature/Title**

Item 42 Signature/Title: The electronic discrete FinCEN Form 8300 is signed when "Sign with PIN" is activated and a valid PIN is entered on the header page. Enter the title of the signer in the Title field.

### **43. Date of signature**

Item 43 Date of signature. This item auto-populates with the current date when the FinCEN Form 8300 is signed with a PIN.

### **44. Contact person**

Item 44 Contact person: Enter the name of the administrative office to be contacted for additional information about the reported transaction.

### **45. Contact telephone number**

Item 45 Contact telephone number: Enter the telephone number to be called to request additional information about the reported transaction.

### **Comments**

Comments: Use this section to clarify or comment on any information entered in Parts I through IV. If Item 32 "Issuer's name(s) and serial number(s)..." or Item 35 "Specific description of property or service..." are too small to

hold all required data, continue those items in the Comments section. If Box 2b "Suspicious transaction" was checked, explain why the transaction was suspicious.

## 10. Attachment D – Secure Data Transfer Mode Filers

FinCEN provides the ability for filers to submit the FinCEN Form 8300 XML batch file securely via the Internet using a VPN device or Connect:Direct software. This method of filing is referred to as Secure Data Transfer Mode (SDTM). SDTM allows for a secure, system to system mechanism for transferring batch submissions from your organization's internal server to the BSA E-Filing server. The batch submission process can be automated such that user intervention/involvement is minimized. There is no interaction with the BSA E-Filing system web site for the upload of the batch file but the BSA E-Filing system web site is used to track the status of the submissions.

For filers using this option for filing, SDTM filers can submit a single file containing the FinCEN Form 8300 XML batch data. The file naming convention is as follows:

**Submission type:** 8300XST

**Date/Time:** This will be a date-time stamp to guarantee filename uniqueness

- Year = YYYY
- Month = MM
- Day = DD
- Hour = hh
- Minute = mm
- Second = ss

**Organization name:** Custom naming by the submitting organization (e.g. "ABCPreparingFirm")

**Extension:** xml

**Example FinCEN Form 8300 XML batch file name:** 8300XST.20170609153015.ABCPreparingFirm.xml

**Corresponding FinCEN Form 8300 XML batch Acknowledgement file name:** This file name will match the corresponding input FinCEN Form 8300 XML batch file name with the text "\*.ACKED" appended to the end.

For example: 8300XST.20170609153015.ABCPreparingFirm.xml.ACKED

For more information on how to setup an SDTM connection, please refer to the SDTM Requirements documentation available on the BSA E-Filing System secure side, or you may contact the BSA E-Filing Help Desk at 1-866-346-9478 or via email at [BSAEFilingHelp@fincen.gov](mailto:BSAEFilingHelp@fincen.gov). The Help Desk is available Monday through Friday from 8 a.m. to 6 p.m. EST. Please note that the Help Desk is closed on Federal holidays.



## 11.Attachment E – Sample Data

Sample data in XML format associated with this form type is available for download [here](#). It include the following:

- InputBatch – A sample input batch XML
- DiscreteFormExamples – Input discrete entry form samples that correspond with an activity in the input batch XML. The file name references the corresponding Activity Sequence Number (SeqNum) in the batch.
- OutputAcknowledgement – A sample XML acknowledgement file that corresponds with the input batch XML.